

Errata

Title & Document Type: 37204A/B HP-IB Extender Operating and Service Manual

Manual Part Number: 37204-90000

Revision Date: July 1986

HP References in this Manual

This manual may contain references to HP or Hewlett-Packard. Please note that Hewlett-Packard's former test and measurement, semiconductor products and chemical analysis businesses are now part of Agilent Technologies. We have made no changes to this manual copy. The HP XXXX referred to in this document is now the Agilent XXXX. For example, model number HP8648A is now model number Agilent 8648A.

About this Manual

We've added this manual to the Agilent website in an effort to help you support your product. This manual provides the best information we could find. It may be incomplete or contain dated information, and the scan quality may not be ideal. If we find a better copy in the future, we will add it to the Agilent website.

Support for Your Product

Agilent no longer sells or supports this product. You will find any other available product information on the Agilent Test & Measurement website:

www.tm.agilent.com

Search for the model number of this product, and the resulting product page will guide you to any available information. Our service centers may be able to perform calibration if no repair parts are needed, but no other support from Agilent is available.

37204A/B
HP-IB EXTENDER

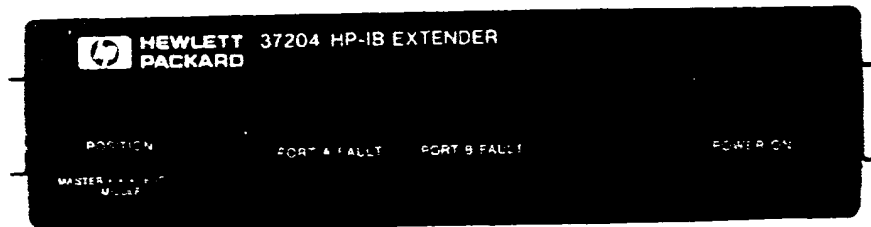

ERRATA

Page 1-2:

Add new text after para 1-7:

"1-8 Retrofitting Options 001, 002

To convert a 37204A standard to Opt 001 order:
Retrofit Kit HP Part No. 37204-60003, Qty 1

To convert a 37204A standard to Opt 002, order:
Retrofit Kit HP Part No. 37204-60003, Qty 1
Transmitter Module HP Part No. 1005-0021, Qty 1
Receiver Module HP Part No. 1005-0005, Qty 1

To convert a 37204A Opt 001 to an Opt 002, order:
Transmitter Module HP Part No. 1005-0021, Qty 1
Receiver Module HP Part No. 1005-0005, Qty 1

Service Note 37204A-1, which is included in the retrofit kit, describes all three of the above upgrades."

*Page 1-2:

Add: OPTION W30 This option is available at the time of purchase and gives 3 year Extended Hardware Support. It provides 2 additional years of return-to-HP hardware service support (for 2nd and 3rd years).

*Page 2-5, Table 2-2:

At FIBER B entry, replace second sentence beginning "Set to NORMAL...." with "Set to FIBER B (up) if using fiber PORT B"

At FIBER A entry, replace second sentence beginning "Set to NORMAL...." with "Set to FIBER A (up) if using fiber PORT A"

ERRATA (continued)

*Page 2-6:

Add new text:

"2-12 Installation Checks

Check that each Extender passes self test:

1. Disconnect all cabling from the 37204A/B. On the rear panel, set the TEST switch to TEST and the fiber switches to NORMAL.
2. Apply power. Check that the POWER lamp lights. Then check that both PORT FAULT lamps flash on briefly then remain off (self test passed). Reset the TEST switch to NORMAL and, if appropriate, set the FIBER switch(es) to FIBER.

Connect up the Extender chain but, for the moment, leave out the HP-IB devices. Power up the Extenders and check that, after blinking on briefly, the PORT FAULT lamps remain off, showing that the Extenders are communicating correctly with each other. (The Extenders talk to each other even though there are no HP-IB devices connected.)

If the Extenders perform the above checks correctly, they are ready to be loaded with HP-IB devices."

*Page 3-2, Paragraph 3-4:

At the end of sub para 1 add: "The Extender chain can contain fiber optic links."

Page 6-7:

Replace 2 lines of text between W1 and MP8 entries with:

"For the 37204B (which adds a 37204-60010 assembly), add MP8 to the 37204A/B Main List."

Page 8-5, Figure 8-1:

On the block diagram of A1:

Label as U2 the HP-IB transceiver between pin 6 of the HP-IB connector and the DAV input to U10.

Also, change U1 pin 4 (upper left) to U1 pin 14.

Page 8-6, Paragraph 8-10-2, Step 2:

Change part number of plastic loop-back cable from 5061-2964 to 5061-2694.

Page 8-13, Step 4, first line:

Change "entify" to "Identify" and delete "Id" at the beginning of the next line.

Page 8-18, Step 5:

Change "10kHz +/-10kHz" to "10MHz +/-10kHz".

ERRATA (continued)

Page 8-20, Table A1-1:

First Column: Change U4(8) to U4(5), U2(8) to U2(5), U1(8) to U1(5),
U3(8) to U3(5).

Third Column: Change U1(18) to U1(15), U4(18) to U4(15), U2(18) to U2(15),
U3(18) to U3(15).

*Page 8-25, Figure A1-6:

Top centre: Change value of C23 from 10uF to 10pF and show C23 as
unpolarised.

Page A-0 (Appendix A):

Swap positions of fuse and voltage selection switches. Switch
settings shown are correct when looking down and with the front
panel on the right.

Page B-1 (Appendix B), 1st Paragraph:

Change part number from 5060-4463 to 5060-4464.

Add at the bottom of the page:

DIMENSIONS:

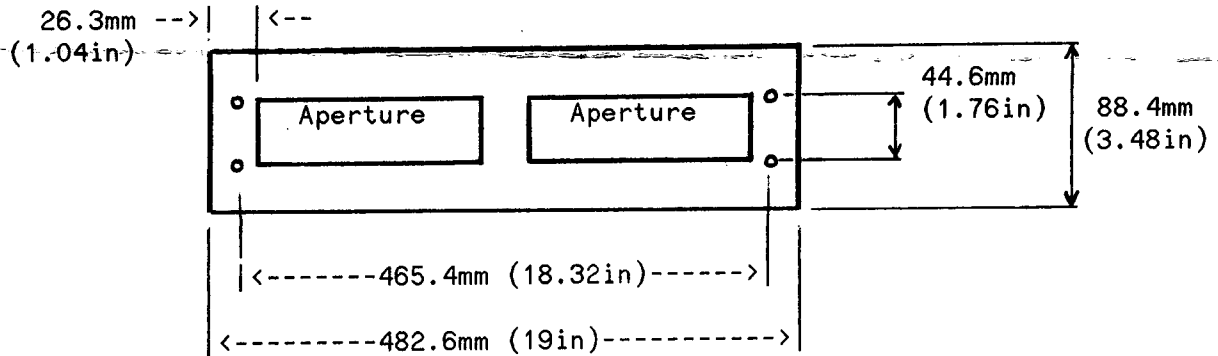

Holes are obround: 7.9 x 11.1mm (.31 x .44in)
Apertures are positioned symmetrically, each 210 x 61mm (8.27 x 2.4in)

ERRATA (continued)

Page B-3 (Appendix B), 1st Paragraph:
 Change part number from 5050-4463 to 5060-4463.
 Add at the bottom of the page:

DIMENSIONS:

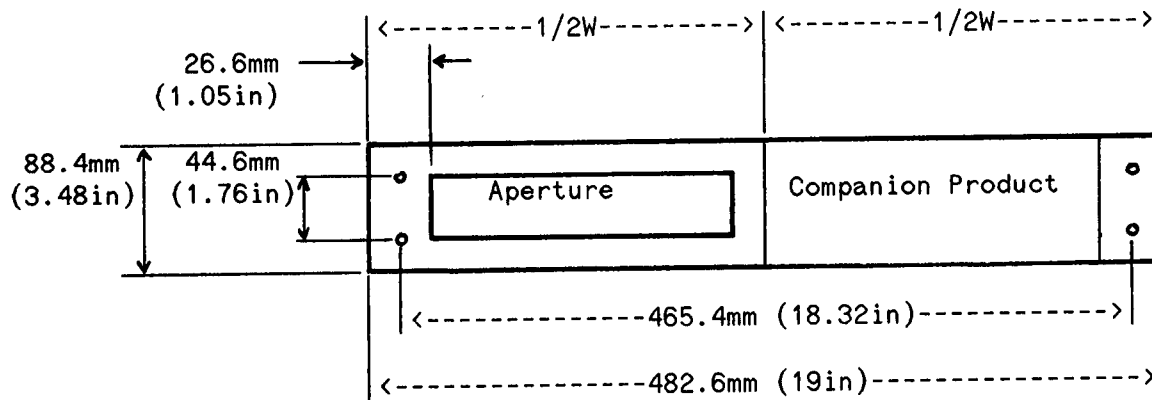

Holes are obround: 7.9 x 11.1mm (.31 x .44in)
 Aperture: 210 x 61mm (8.27 x 2.4in)



**HEWLETT
PACKARD**

OPERATING & SERVICE MANUAL

37204A/B HP-IB EXTENDER

SERIAL NUMBERS

This manual applies directly to instruments with serial numbers prefixed 2547U.

For additional important information about Serial numbers, see SERIAL NUMBER/
MANUAL CHANGES in Section 1.

©Copyright HEWLETT-PACKARD LIMITED 1986
SOUTH QUEENSFERRY, WEST LOTHIAN, SCOTLAND

Manual Part Number : 37204-90000
Microfiche Part Number : 37204-90025

Printed : July 1986

LIST OF CONTENTS

SECTION 1 GENERAL INFORMATION

Paragraph

1-1 INTRODUCTION	Page 1-1
1-2 MODELS COVERED	1-1
1-3 OPTIONS	1-1
1-4 SERIAL NUMBER/MANUAL CHANGES	1-2
1-5 SPECIFICATIONS	1-2
1-6 RECOMMENDED TEST EQUIPMENT	1-2
1-7 WARRANTY CONVERSION	1-2

Table

1-1 RECOMMENDED TEST EQUIPMENT	1-3
--	-----

SECTION 2 INSTALLATION

Paragraph

2-1 INTRODUCTION	2-1
2-2 INITIAL INSPECTION	2-1
2-3 AC VOLTAGE SELECTION	2-1
2-4 POWER CORD	2-1
2-5 RACK MOUNTING	2-2
2-6 PLANNING THE HP-IB EXTENDER CHAIN	2-2
2-7 SPECIFICATIONS OF THE CABLE LINK BETWEEN EXTENDERS	2-2
2-8 CABLE CONNECTIONS BETWEEN EXTENDERS	2-4
2-9 SETTING THE FRONT PANEL SWITCH	2-5
2-10 SETTING REAR PANEL CONFIGURATION SWITCHES	2-5
2-11 CONNECTION OF HP-IB DEVICES TO EXTENDERS	2-6

Table

2-1 CO-AXIAL AND FIBER OPTIC CABLE SPECIFICATIONS Page 2-4
2-2 REAR PANEL CONFIGURATION SWITCHES 2-5
2-3 HP-IB INTERCONNECTING CABLE 2-6

Figure

2-1 37204A/B HP-IB EXTENDER FRONT PANEL 2-0
2-2 37204A/B HP-IB EXTENDER REAR PANEL 2-0
2-3 37204A/B EXTENDER CONFIGURATIONS. 2-3

SECTION 3 OPERATION

Paragraph

3-1 INTRODUCTION 3-1
3-2 TRANSPARENCY OF EXTENDERS. 3-1
3-3 HP-IB HANG-UP ON LOSS OF COMMUNICATION 3-1
3-4 TRUNCTION. 3-2
3-5 PARALLEL POLL RESPONSE. 3-3
3-6 EXTENDER IS A LISTEN ALWAYS DEVICE. 3-3
3-7 DATA THROUGHPUT 3-3

Figure

3-1 TRUNCATION IN STAR NETWORKS 3-3

SECTION 4 PERFORMANCE VERIFICATION

Paragraph

4-1 INTRODUCTION 4-1
4-2 EQUIPMENT REQUIRED 4-1
4-3 COMPUTER HP-IB INTERFACES 4-1
4-4 TEST CONFIGURATION 4-2
4-5 PERFORMANCE VERIFICATION PROGRAM 4-3

Figure

4-1 PERFORMANCE TEST TYPICAL CONFIGURATION Page 4-3

SECTION 5 ADJUSTMENTS
(None required)

SECTION 6 REPLACEABLE PARTS

Paragraph

6-1 INTRODUCTION 6-1
6-2 ORDERING INFORMATION 6-1

Table

6-1 EXCHANGE ASSEMBLY 6-1
6-2 REPLACEABLE PARTS 37204A/B MAIN LIST 6-2
6-3 REPLACEABLE PARTS ASSEMBLY A1 6-2
6-4 REPLACEABLE PARTS ASSEMBLY A2 6-6
6-5 REPLACEABLE PARTS ASSEMBLY A10. 6-7

SECTION 7 MANUAL CHANGES

Paragraph

7-1 INTRODUCTION 7-1

SECTION 8 SERVICE

Paragraph

8-1 INTRODUCTION 8-1
8-2 PREVENTIVE MAINTENANCE 8-1
8-3 FAULT ISOLATION 8-1
8-4 SAFETY REQUIREMENTS. 8-2
8-5 RECOMMENDED TEST EQUIPMENT 8-2
8-6 REPAIR 8-2

8-7	CO-AXIAL CABLE REPAIR	Page 8-2
8-8	FIBER OPTIC CABLE REPAIR	8-2
8-9	DESCRIPTION OF SELF TEST.	8-3
8-9-1	Introduction.	8-3
8-9-2	Co-Axial Ports	8-3
8-9-3	HP-IB Interface	8-3
8-9-4	Fiber Optic	8-4
8-10	RUNNING SELF TEST	8-6
8-10-1	Testing the COAX Ports.	8-6
8-10-2	Testing the Fiber Optic Ports.	8-6

Figure

8-1	BLOCK DIAGRAM OF 37204A SHOWING SELF TEST LOOPBACK PATHS.	8-5
-----	---	-----

Paragraph

G1	SYSTEM TROUBLESHOOTING	8-7
G1-1	FAULTY EXTENDER CHAIN OR HP-IB DEVICE?.	8-7
G1-1-1	All Port Fault Lamps Off.	8-7
G1-1-2	One or More PORT FAULT Lamps On.	8-7
G1-2	TROUBLESHOOTING WITHIN THE EXTENDER CHAIN	8-8
G1-2-1	Background	8-8
G1-2-2	Locating The Faulty Extender or Cable Link.	8-10

Figure

G1-1	LOCATING A TRUNCATING EXTENDER.	8-8
G1-2	PORT FAULT LAMP INDICATIONS CAUSED BY INTERMITTENT ERRORS.	8-9
G1-3	PORT FAULT LAMP INDICATIONS CAUSED BY A CONTINUOUS FAILURE.	8-11

Paragraph

G2	INSTRUMENT TROUBLESHOOTING	8-13
G2-1	DETERMINING WHICH ASSEMBLY IS FAULTY.	8-13
G2-2	A1 ASSEMBLY REPLACEMENT PROCEDURE.	8-16

Table

G2-1 A2 FIBER OPTIC ASSEMBLY: FIELD REPLACEABLE PARTS Page 8-14

Figure

G2-1 ASSEMBLY RETAINING SCREWS 8-15

Paragraph

A1 HP-IB EXTENDER MAIN ASSEMBLY 8-17
A1-1 INTRODUCTION 8-17
A1-2 CIRCUIT DESCRIPTION 8-17
A1-2 CIRCUIT DESCRIPTION 8-17
A1-3 TROUBLESHOOTING PROCEDURE. 8-18

Table

A1-1 U10 HP-IB LOOPBACK TESTING SEQUENCE. 8-20

Figure

A1-1 A1 COMPONENT LOCATION. 8-22
A1-2 U10 PIN LOCATION. 8-22
A1-3 A1 POWER SUPPLY. 8-23
A1-4 A1 COMPONENT LOCATION. 8-24
A1-5 U10 PIN LOCATION 8-24
A1-6 A1 EXTENDER LOGIC AND DRIVER/RECEIVERS 8-25

Paragraph

A2 FIBER OPTIC ASSEMBLY 8-27
A2-1 INTRODUCTION 8-27
A2-2 CIRCUIT DESCRIPTION 8-27
A2-3 TROUBLESHOOTING PROCEDURE. 8-28

Table

A2-1 LOOPED BACK TEST SIGNALS. 8-29

Figure

A2-1 A2 COMPONENT LOCATION 8-32
A2-2 FIBER OPTIC DRIVER/RECEIVERS 8-33

Paragraph

A10 EXTENDED POWER FAIL ASSEMBLY 8-35
A10-1 INTRODUCTION 8-35
A10-2 CIRCUIT DESCRIPTION Page 8-35
A10-3 TROUBLESHOOTING PROCEDURE 8-35

Figure

A10-1 POWER FAIL TIMER 8-34
A10-2 A10 COMPONENT LOCATION 8-34

APPENDIX A

LINE VOLTAGE SELECTION A-1

Figure

A-1 LINE VOLTAGE AND FUSE SELECTION A-0

APPENDIX B

RACK MOUNTING 37204A/B EXTENDERS B-1
RACK MOUNTING WITH HP SYSTEM 2 CABINETS B-3

Figure

B-1 REMOVING THE FRONT PANEL TRIM B-0
B-2 INVERTING THE FRONT PANEL TRIM B-0
B-3 MOUNTING IN A 19 INCH RACK B-2
B-4 SYSTEM 2 CABINET RACK MOUNTING B-2

General Information

1-1 Introduction

This manual contains information to install, operate, test and service your 37204A/B HP-IB Extender. 37204A/B Extenders provide single-point and multi-point extension of the Hewlett Packard Interface Bus (HP-IB), and allow the distance between devices using this interface to be increased well beyond the limits imposed by direct HP-IB cabling.

HP-IB is Hewlett Packard's implementation of the IEEE 488 and IEC 625 Interface standards. The 37204A/B can be used to extend these interfaces.

1-2 Models Covered

This manual covers the 37204A including options 001, 002, and the 37204B. Functionally, the only difference between the 37204A and 37204B is that the 37204B's power fail reset lasts approximately 1.5s compared with less than 0.1s for the 37204A. The extended reset of the 37204B is required by certain HP computers to ensure proper power fail recovery in the event of a momentary power loss.

Unless specifically stated otherwise, the information in this manual applies to both the A and B versions of the 37204 HP-IB Extenders.

1-3 Options

Options 001 and 002 add fiber optic capability to the 37204A. Fiber optic cable removes the metallic connection between Extenders, providing complete electrical isolation between Extenders. Typical benefits are: excellent lightning protection out of doors; and the avoidance of sparks in explosive environments.

Option 001 - Adds fiber optic capability to Port A.

Option 002 - Adds fiber optic capability to Ports A and B.

Note : Options 001 and 002 are not available on the 37204B.

1-4 Serial Number/Manual Changes

Attached to the rear of the 37204A/B is a serial number plate. The first 4 digits and the letter are the serial number prefix, and are changed only when a change is made to the Extender. The remaining digits are assigned sequentially and are unique to each Extender. The title page of this manual lists the serial prefixes of the Extenders covered. Extenders manufactured after the printing of this manual may have a serial prefix that is not listed on the title page. In this case, the manual is accompanied by a Manual Change which documents the differences between the Extender and this manual.

1-5 Specifications

Maximum Distance:	1250 meters per link, coax or fiber optic.
Maximum Speed:	60k bytes/s.
Power Requirements:	100/120/220/240 Volts ac +5/-10%. 48 to 66Hz. 10VA max.
Temperature Ranges:	0°C to 55°C (Operating). -40°C to 75°C (Storage).
Dimensions:	Height 71mm, width 212mm, depth 254mm
Weight:	1.72kg.

1-6 Recommended Test Equipment

Equipment required to service the 37204A is listed in Table 1-1. Other equipment may be substituted if it meets or exceeds the critical specifications listed in the table.

1-7 Warranty Conversion

Option W03 converts the standard 12-month bench warranty (see inside of front cover) into a 90-day on-site warranty. Contact your nearest Hewlett-Packard office for details of the conversion and if it is available in your country.

Table 1-1 Recommended Test Equipment

Instrument	Critical Specifications	Recommended Model	Use*
Oscilloscope	100MHz bw	HP 1740A	T
Frequency Counter	Frequency range 10Hz to 30MHz	HP 5382A	T
Digital Multimeter	± 0.1 at $\pm 5V$	HP 3435A	T
Desktop Computer	Unique	HP 9000 Ser 200	P
Interface Card	Unique	HP 98624A	P
IIPL Operating Language	Unique	HP 98614A	P
Performance Verification Disc	Unique	HP 37203-12105	P
Logic Probe	TTL Compatible	HP 545A	T

* A = Adjustments, P = Performance Tests, T = Troubleshooting

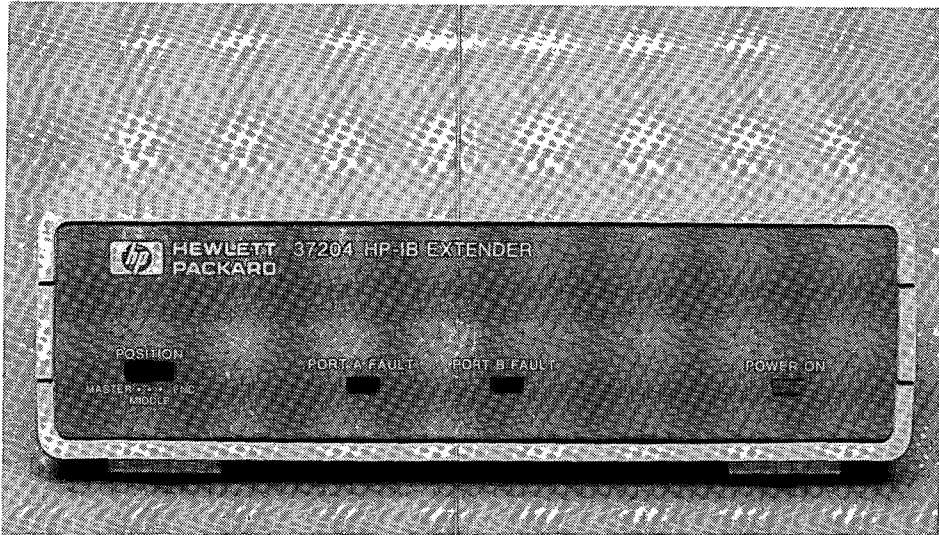

Figure 2-1 37204A/B HP-IB Extender Front Panel

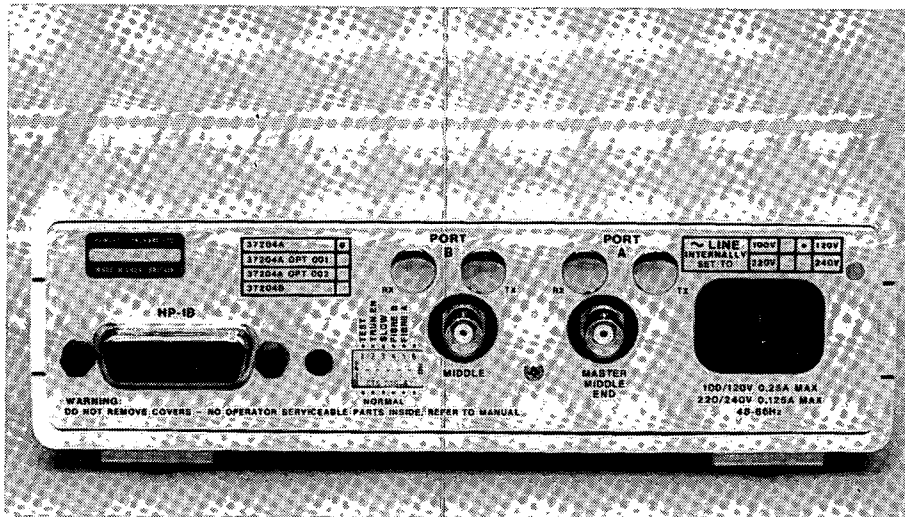

Figure 2-2 37204A/B HP-IB Extender Rear Panel

Installation

2-1 Introduction

Procedures for the installation of your 37204A/B HP-IB Extender are given in this section. If any difficulty is encountered, contact your nearest Hewlett Packard office.

2-2 Initial Inspection

Your Extender has been checked both mechanically and electrically before dispatch, and is shipped in specially designed packing to provide protection during shipment. However, if the packaging shows obvious signs of damage, check the contents of the shipping carton for completeness and/or damage. If there is any damage or missing parts, retain the shipping carton for the carrier's inspection and inform your nearest Hewlett Packard office immediately. The Hewlett Packard office will arrange for repair or replacement of your Extender without waiting for the settlement of any claim against the carrier.

2-3 AC Voltage Selection

The required ac power line voltage for your Extender is marked on the rear panel immediately above the power cord inlet. Your Extender is shipped to you with the ac voltage setting as specified in your order. If you need to configure the Extender for a different voltage range, refer to Appendix A of this manual.

2-4 Power Cord

The type of power cord supplied with your Extender varies with the country of destination. If the power cord supplied is not suitable for use in your country, contact your nearest Hewlett Packard office and a replacement will be provided.

2-5 Rack Mounting

If you wish to rack mount your Extender, refer to the instructions in Appendix B of this manual.

2-6 Planning the HP-IB Extender Chain

Install an Extender at each node where HP-IB devices are clustered. The maximum length of cable allowed per link is:

Fiber optic	= 1250 meters (4000 ft)
Coax (NORMAL mode)	= 250 meters (800 ft)
Coax (SLOW speed)	= 1250 meters (4000 ft)

If you require a very long cable link, you can insert Extenders (with no HP-IB devices attached) at suitable intermediate positions to ensure that the maximum length between nodes is not exceeded. Figure 2-3 illustrates typical HP-IB Extender chains. A single co-axial cable or, optionally, dual fiber optic cables provide the serial link between adjacent Extenders.

An Extender chain can contain up to 30 Extenders.

2-7 Specification of the Cable Link between Extenders

You may use any co-axial cable meeting the specifications listed in Table 2-1 as the link between Extenders. Cable with a higher attenuation may be used provided the total attenuation of the cable does not exceed 17.25dB @ 100MHz for NORMAL speed or 86.25dB @ 100MHz for SLOW speed operation. Splices in co-axial cable do not normally introduce sufficient attenuation to affect maximum cable runs and may be ignored.

You must use the recommended Hewlett Packard fiber optic cable specified in Table 2-1. Splices (joins) in a fiber optic cable introduce optical attenuation approximately equivalent to a 200 meter length of cable. The 1250 meter maximum length of fiber optic cable includes an allowance for a single splice (for repair of a damaged cable).

SINGLE POINT CONFIGURATION

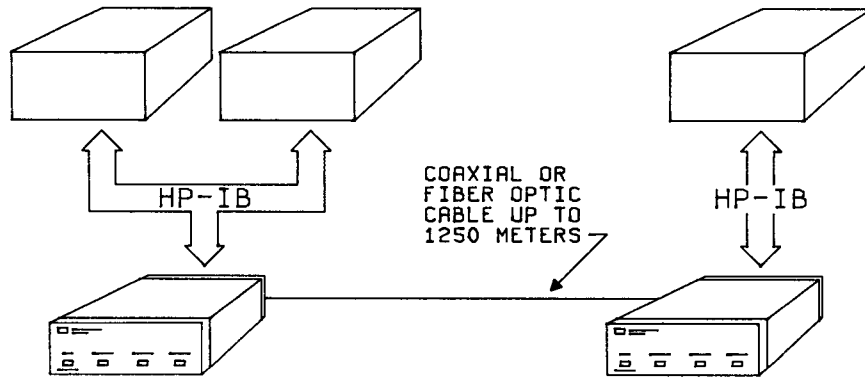

MULTI-DROP CONFIGURATION

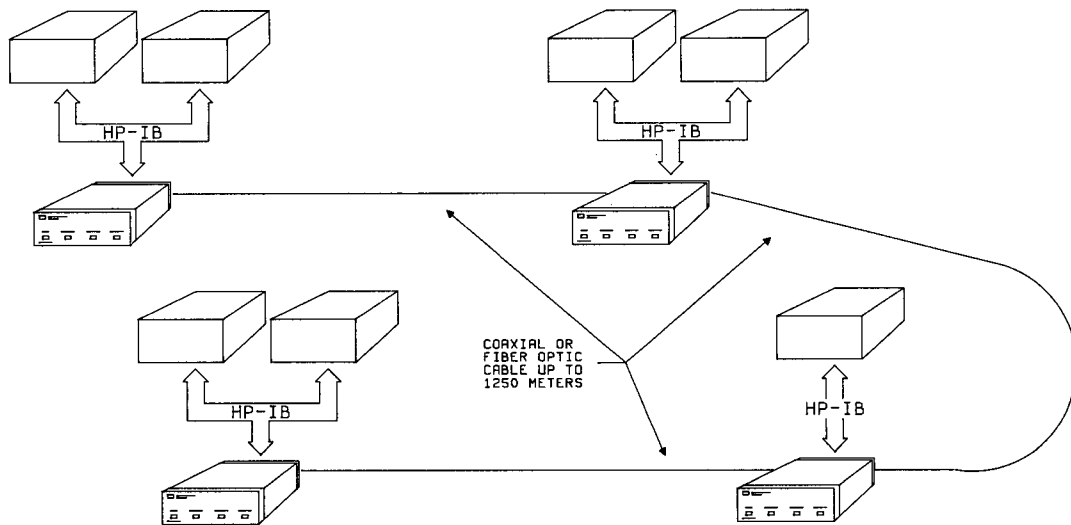

Figure 2-3 37204A/B Extender Configurations

Table 2-1 Co-Axial And Fiber Optic Cable Specifications

Co-Axial Cable	Fiber Optic Cable
Impedance : 75 ohm Loss/100 meters:< 6.9db @ 100MHz Connector : 75 ohm BNC	1 X HP 39200B Duplex Optical Cable Assy or 2 X HP 39200A Single Optical Cable Assy Optical Connector: HFBR 4000
Recommended Types: Cable - Belden 9248 Connector - Trompeter UPL 20-41	(Order cable with option 001 and specify the length in meters. Cable will come fitted with connectors.)

2-8 Cable Connection between Extenders

For Extenders located at the ends of the chain (i.e. the MASTER and the END Extenders), always connect the co-axial cable to the PORT A connector at the rear of the 37204A/B. For MIDDLE Extenders, connect the cables either way round to PORT A and PORT B.

The same rules apply to fiber optic links except that separate optical transmitter and receiver connectors are provided (located immediately above the corresponding co-axial connector).

CAUTION

DO NOT USE EXCESSIVE FORCE TO TIGHTEN THE OPTICAL CONNECTORS. SCREW THE CONNECTORS DOWN FINGER TIGHT (0.05 TO 0.1 NEWTON-METERS) OTHERWISE DAMAGE MAY RESULT. ALSO ENSURE THAT THE BARREL ON THE CONNECTOR IS NOT ROTATED AS YOU TIGHTEN DOWN (OR RELEASE) THE CONNECTOR: TWISTING OF THE OPTICAL CABLE MAY CAUSE DAMAGE.

2-9 Setting the Front Panel Position Switch

Set the front panel POSITION switch to MASTER at one end of the chain and to END at the other end. Set all other Extenders in the chain to MIDDLE. If there are only two Extenders in the chain, set one to MASTER and the other to END.

If the truncation feature is enabled (see para 3-4), locate the HP-IB system controller at the MASTER Extender. When truncation is not enabled, locate the HP-IB system controller at any convenient Extender.

2-10 Setting Rear Panel Configuration Switches

Set the 37204A/B operating configuration using the switch bank mounted on the rear panel (See Table 2-2). The rightmost switch is unused.

Table 2-2 Rear Panel Configuration Switches

TEST	Set to NORMAL (down) position. TEST position runs Extender self test as explained in Section 8.
TRUN.EN	Set to NORMAL (down) unless HP-IB truncation feature is required.
SLOW	Sets the speed of the serial data link between Extenders. Select SLOW at all Extenders if any co-axial cable link between Extenders exceeds 250 meters.
FIBER B	Selects between co-axial cable and fiber optic on port B. Set to NORMAL (down) if fiber optic option is not fitted to Port B.
FIBER A	Selects between co-axial cable and fiber optic on port A, Set to NORMAL (down) if fiber optic option is not fitted to Port A.

2-11 Connection of HP-IB Devices to Extenders

Each Extender can have up to 14 HP-IB devices connected to the rear panel HP-IB connector. The total length of HP-IB cable used at each 37204A/B Extender site must meet the normal restrictions on HP-IB cabling, ie less than or equal to 2 meters (6.56 ft) times the number of directly connected devices, subject to a maximum length of 20 meters (65.6 ft). Table 2-3 lists HP-IB interconnecting cables available from Hewlett-Packard.

Table 2-3 HP-IB Interconnecting Cable

Length	Accessory Number
0.5 meter	HP 10833D
1 meter	HP 10833A
2 meter	HP 10833B
4 meter	HP 10833C

Operation

3-1 Introduction

Once installed, a 37204A/B HP-IB Extender chain operates entirely automatically. In most cases, the "transparency" of the Extender network ensures that the user does not detect any difference between a directly connected HP-IB system and an extended HP-IB system. The purpose of this section is to provide additional information on the operating characteristics of the Extenders.

3-2 Transparency of Extenders

The 37204A/B supports the full range of HP-IB functions. Consequently, users will find that when Extenders are installed in an HP-IB system, there is no need to modify controller software except, perhaps, for increasing the time of a parallel poll response. (The parallel poll feature of HP-IB is not normally found in instrument systems).

The 37204A/B works with all devices which fully comply with IEEE Standard 488-1978. Devices that do not comply, especially those which do not properly implement the 3-wire handshake, may cause the Extender network to operate unreliably. **DO NOT ASSUME, THEREFORE, WHEN DEVICES WORK WITHOUT EXTENDERS BUT NOT WITH EXTENDERS, THAT THE EXTENDER IS THE CAUSE OF THE PROBLEM.**

3-3 HP-IB Hang-up On Loss Of Communication

In an HP-IB system, data is transferred between devices by means of an interlocking 3-wire handshake. Maintaining this protocol in an extended system means that each stage of the handshake must be completed at all Extender nodes before the next HP-IB transaction can take place. To prevent breakdown in any one Extender link from

hanging up the entire HP-IB network, the user can choose to enable the truncation feature.

3-4 Truncation

In applications where this is known to be useful, truncation allows a partial HP-IB system to continue with reduced operation when an Extender link fails. The system controller can restore normal HP-IB operation on the system controller's local HP-IB bus and, if co-axial cable is used in the Extender chain, truncation can include all remote HP-IB busses located before the communication break.

Truncation is enabled by a rear panel switch (see Para 2-10). There is a choice of configuration:

1. Truncation enabled on the master Extender only. A failure anywhere in the Extender chain truncates the chain to the master HP-IB Extender.
2. Truncation enabled on all Extenders in the chain. The chain truncates at the Extender immediately before the failing Extender/link. The Extender chain must not contain any fiber optic links.

A truncation attempt is triggered every time the system controller asserts IFC (Interface Clear) with the TRUN.EN switch set. Extenders with truncation enabled check that messages are being echoed back from the next Extender in the chain. If messages are not being echoed back, the Extender truncates the chain at the failing port. Once enabled, truncation remains in effect until the next time IFC is asserted at which time the echo check is repeated. If communication is restored, truncation is removed; if not, truncation remains.

Note: Truncation cannot be instigated by any method other than a fault in communication.

When truncation is enabled at all Extenders, one assertion of IFC is sufficient to force truncation. However, to guarantee removal of truncation, IFC must be asserted the same number of times as there are Extenders in the chain. Each assertion of IFC must be separated by at least 2ms (NORMAL speed) or 20ms (SLOW speed) to allow time for truncation to be removed at each Extender node. If the chain contains a fiber link, then the assertions of IFC must be separated by at least 3 seconds.

Note: Truncation occurs only if there is a communication loss within the Extender chain. HP-IB hang-ups or loss of power on an HP-IB device connected to an Extender does not affect communication between Extenders and therefore does not cause truncation.

Truncation is useful when Extenders are connected in star configuration as shown in Figure 3-1. Without truncation, a failure in any Extender chain will hang all Extender chains until the fault is cleared. With truncation enabled at each master Extender, the failing chain is truncated at the master Extender when IFC is asserted, allowing normal operation for the rest of the system.

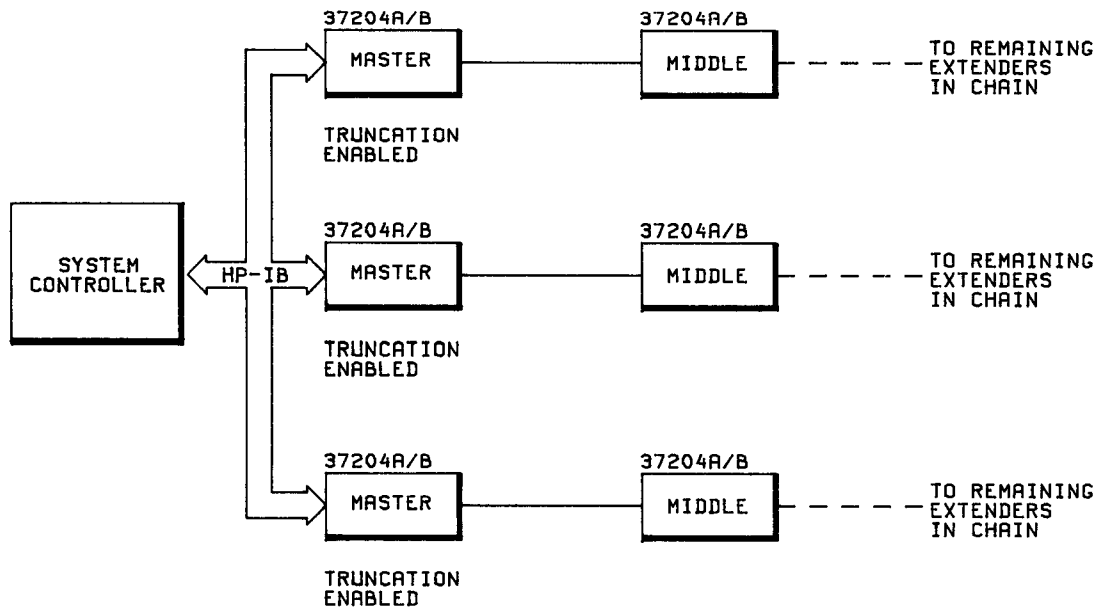

Figure 3-1 Truncation in Star Networks

3-5 Parallel Poll Response

The 37204A/B supports Parallel Polling as defined in the IEEE 488 standard but, due to the delays caused by the Extender chain, the response to a parallel poll will not be within 2us as specified by the IEEE 488 standard. Calculate the maximum time for a parallel poll response by allowing 22us for the first Extender link + 24us for each additional Extender link in the system. These times are for Extenders set to NORMAL speed. For Extenders set to SLOW speed, increase the times to 220us and 240us, respectively. Make a further allowance for the propagation delay in the cabling between Extenders at the rate of 1.7us/100 meters (2.0us/100 meters for fiber optic cable).

Note: The parallel poll response time for devices on the system controller's local bus is not affected by the Extender system.

3-6 Extender Is A Listen Always Device

In an HP-IB Extender system, the HP-IB data from the talker (sourcing) device is made available at all Extender sites irrespective of whether there are devices addressed to listen at those sites. Hence, an Extender always accepts data from a talking device even though there are no addressed listeners in the system, ie it will appear that there is a "listen always" device in the system.

3-7 Data Throughput

The maximum data transfer rate of an HP-IB Extender network is difficult to calculate with precision. It depends, for example, on the response times of the devices in the system, the number of Extender nodes and the distance between nodes. Some points:

1. Each Extender link increases the handshake time for a single byte by approximately 16us when set to NORMAL speed and 160us when set to SLOW. The delay introduced by the cabling between Extenders is calculated at 0.017us/meter for co-axial cable and 0.020us/meter for fiber optic cable.
2. To predict the data rate in an extended system, find the time required to handshake a single byte in the un-extended system and add to this the additional time introduced by the Extenders and cabling. (The rate of the extended system is then the inverse of this sum).

Example 1

Two devices with a data transfer rate of 50,000 bytes/s are connected via a pair of HP 37204A/B Extenders and 200 meters of co-axial cable.

Time required for single byte transfer
without Extenders = $1/50,000$ s

$$= 20\mu\text{s}$$

Data transfer time of the Extenders = $(16 \times 1) + (0.017 \times 200)\mu\text{s}$

$$= 19\mu\text{s}$$

Total data transfer time = $19 + 20\mu\text{s}$

$$= 39\mu\text{s}$$

Therefore predicted transfer data
rate = $1/39 \times 10^{-6}$ bytes/s

$$= 25\text{k bytes/s, approximately.}$$

Example 2

Data Transfer rate in an "un-extended" system is 20,000 bytes/s. The system is extended by means of 4 chained Extenders. The combined length of cable between Extenders is 250 meters.

Time required for a single byte
transfer without Extenders = $1/20,000$ s

$$= 50\mu\text{s}$$

Data transfer time of the Extenders = $(16 \times 3) + (0.017 \times 250)\mu\text{s}$

$$= 52.25\mu\text{s}$$

Total data transfer time = $50 + 52.25\mu\text{s}$

= 102.25us

Therefore predicted transfer data rate

= $1/102.25 \times 10^{-6}$ bytes/s

= 10k bytes/s, approximately.

Note: In some instances, the handshake time contributed by a device is itself influenced by the speed of the devices in the system.

Performance Verification

4-1 Introduction

The performance verification test described in this section checks out a 37204A/B Extender chain to ensure that it is capable of providing transparent HP-IB extension.

Note : Self test is thorough and easy to use. For most purposes, it is an adequate check on the 37204A/B, making the performance tests detailed in this section unnecessary.

4-2 Equipment Required

In addition to the 37204A/B Extenders chain under test, an HP 9000 Series 200 Desktop computer with the following specifications is required:

HPL Operating language
Internal HP-IB Interface
HP98624A HP-IB Interface Card

The test program is written in HPL and is available on a 5 1/4 inch floppy disc (HP Part No. 37203-12105).

4-3 Computer HP-IB Interfaces

The computer requires two separate HP-IB Interfaces which must be configured as follows:

HP-IB Interface Configuration

	Interface 1 (Default)	Interface 2 (Altered)
Select Code	7	8
HP-IB Address	21	22
System Controller	ON	OFF

4-4 Test Configuration

Run the performance test to verify either single point HP-IB extension (two 37204A/Bs), or multi-point HP-IB extension (three or more 37204A/Bs). 37204As and 37204Bs are functionally similar and an Extender chain may contain both types of Extender.

1. Cable the 37204A/B Extenders together using co-axial or fiber optic cable as appropriate. Connect to the master and end Extenders at their A PORTs. It does not matter which way around the cable connections are made to the middle Extenders.
2. Set the front panel POSITION switches to MASTER, END and MIDDLE as appropriate.
3. Set all the rear panel switches to NORMAL. If fiber optic cable is used, set the appropriate rear panel switches to FIBER.
4. Power-up the Extenders and check that all POWER lamps are illuminated and that all PORT FAULT lamps are off. If a PORT FAULT lamp is on at any Extender, check for a faulty Extender or cable link (refer to Section 8).
5. Connect the computer HP-IB interface with select code 7 (System Controller) to the master 37204A/B.
6. Connect the other HP-IB interface to any other 37204A/B in the chain. It does not matter if some Extenders in the chain are not connected to an HP-IB device.

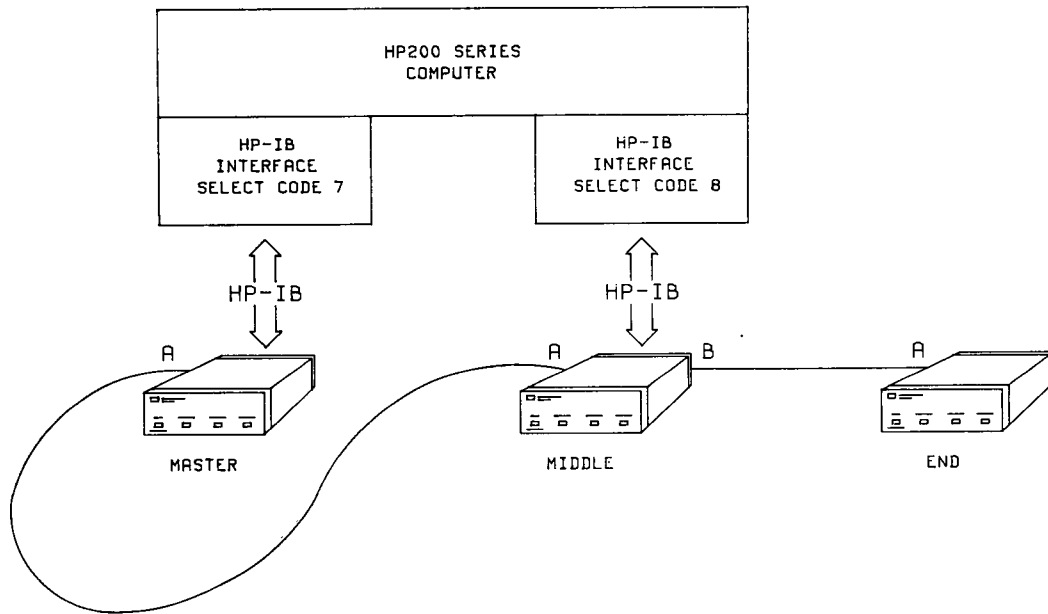

Figure 4-1 Performance Test Typical Configuration

4-5 Performance Verification Test Program

The program name is P203/4. Run the program to get instructions.



Adjustments

There are no adjustments on this instrument.



Replaceable Parts

6-1 Introduction

This section contains information on replaceable parts for the 37204A/B HP-IB Extenders. Parts are listed in alphanumeric order. A check digit (CD) is given for each part number. This digit is numerically derived from the part number and is used by Hewlett Packard to check the validity of part numbers. Against the first occurrence of each part number in the parts listing, is given the total quantity (QTY) of that part used.

6-2 Ordering Information

To order a listed part, quote the HP part number, indicate the quantity required and send the order to your nearest Hewlett Packard office. To order a part not listed, send a description of the part together with the model and serial number to your nearest Hewlett Packard office.

Table 6-1 Exchange Assembly

Assembly Name	New Assembly Part No.	Exchange Assembly Part No.
HP-IB Extenders Assembly	37204-60001	37204-69001

Table 6-2 Replaceable Parts 37204A/B Main List

Reference Designator	HP Part Number	C D	Qty	Description
MP1	37204-00001	0	1	Front Panel
MP2	37204-00002	1	1	Rear Panel
MP3	37204-60021	0	1	Top Cover (fitted with magnetic screen)
MP4	37204-00005	4	1	Bottom Cover
MP5	37204-40001	4	2	End Moldings
MP6	0403-0179	0	4	Feet

Table 6-3 Replaceable Parts Assembly A1

Reference Designator	HP Part Number	C D	Qty	Description
A1	37204-60001	6	1	Board Assembly
C1	0160-4574	3	2	C Fxd 1000pF 10% 100V
C2	0160-4574	3		C Fxd 1000pF 10% 100V
C3	0180-3802	8	1	C Fxd 10,000uF 25V AL
C4	0180-0374	3	1	C Fxd 10uF 20V TA
C5	0160-3879	7	2	C Fxd 0.01uF 20% 100V
C6	0160-3879	7		C Fxd 0.01uF 20% 100V
C7	0160-4835	7	15	C Fxd 0.1uF 10% 50V
C8	0160-4835	7		C Fxd 0.1uF 10% 50V
C9	0160-4835	7		C Fxd 0.1uF 10% 50V
C10	0160-4835	7		C Fxd 0.1uF 10% 50V
C11	0160-4835	7		C Fxd 0.1uF 10% 50V
C12	0160-4835	7		C Fxd 0.1uF 10% 50V
C13	0160-4835	7		C Fxd 0.1uF 10% 50V
C14	0160-4835	7		C Fxd 0.1uF 10% 50V

Table 6-3 Replaceable Parts Assembly A1 (Continued)

Reference Designator	HP Part Number	C D	Qty	Description
C15	0160-4835	7		C Fxd 0.1uF 10% 50V
C16	0160-4835	7		C Fxd 0.1uF 10% 50V
C17	0160-4835	7		C Fxd 0.1uF 10% 50V
C18	0160-4835	7		C Fxd 0.1uF 10% 50V
C19	0160-4835	7		C Fxd 0.1uF 10% 50V
C20	0160-4835	7		C Fxd 0.1uF 10% 50V
C21	9135-0150	7	1	C Fxd 0.15uF + 2 X 4700pF
C22	0160-4835	7		C Fxd 0.1uF 10% 50V
C23	0160-3874	2	1	C Fxd 10pF 5% 200V
CR1	1901-0662	3	2	DIO PWR RECT 5A 100V
CR2	1901-0662	3		DIO PWR RECT 5A 100V
CR3	0837-0204	1	1	VARISTOR 24V
CR4	1902-3097	6	1	ZNR 5.23V 2%
CR5	1990-0618	6	2	LED (Red)
CR6	1990-0618	6		LED (Red)
CR7	1990-0943	0	1	LED (Green)
F1	2110-0269	0	2	FUSE HLDR (Clip)
	5040-3081	4	1	FUSE HLDR (Cover)
	2110-0318	0	1	FUSE 0.125A 250V Timed (220/240V)
	2110-0201		1	FUSE 0.250A 250V Timed (100/120V)
J1	1251-7651	5	1	HP-IB Connector
J4	1251-4743	0	1	Power Connector
J5	1200-1277	2	1	A2 / A10 Board Connector
J6	1250-2001	7	2	BNC Connector (Port B)
J7	1250-2001	7		BNC Connector (Port A)
J8	1251-4631	5	3	LED Connector
J9	1251-4631	5		LED Connector
J10	1251-4631	5		LED Connector
MP1	37204-00016	7	1	HEATSINK

Table 6-3 Replaceable Parts Assembly A1 (Continued)

Reference Designator	HP Part Number	C D	Qty	Description
R1	0698-0082	7	3	R Fxd 464 ohm 1% 0.125W
R2	0698-0082	7		R Fxd 464 ohm 1% 0.125W
R3	0698-0082	7		R Fxd 464 ohm 1% 0.125W
R4	0757-0442	9	2	R Fxd 10K ohm 1% 0.125W
R5	0757-0442	9		R Fxd 10K ohm 1% 0.125W
S1	3101-0493	4	1	MASTER-MIDDLE-END switch
S2	3101-2844	3	1	DIP Switch (6 switches)
S3	3101-2616	7	2	Switch, Voltage Select
S4	3101-2616	7		Switch, Voltage Select
T1	37204-80001	8	2	XFMR, Pulse
T2	37204-80001	8		XFMR, Pulse
T3	9100-4474	3	1	XFMR, Power
	37212-00020	3	1	Magnetic Screen
U1	1820-1689	4	4	ICD MC3446
U2	1820-1689	4		ICD MC3446
U3	1820-1689	4		ICD MC3446
U4	1820-1689	4		ICD MC3446
U5	1820-0535	7	2	ICD SN75451
U6	1820-0535	7		ICD SN75451
U7	1820-4138	4	2	ICD SN75175
U8	1820-4138	4		ICD SN75175
U9	1826-0122	0	1	ICR 7805
U10	37204-80003	0	1	ICD Gate Array
	1251-0600	0	1	Socket for U10
U11	1810-0162	5	1	R Netwk 13 X 4.7K ohm
U12	37204-80002	9	1	R Netwk Special

Table 6-4 Replaceable Parts A2 Assembly

Reference Designator	HP Part Number	C D	Qty	Description
A2	37204-60002	7	1	Fiber Optic Board Assembly
C1	0160-4835	7	2	C Fxd 0.1uF 10% 50V
C2	0180-2815	1	1	C Fxd 100uF 10V TA
C3	0180-2816	2	4	C Fxd 68uF 10V TA
C4	0180-2816	2		C Fxd 68uF 10V TA
C5	0180-2816	2		C Fxd 68uF 10V TA
C6	0180-2816	2		C Fxd 68uF 10V TA
C7	0160-4835	7		C Fxd 0.1uF 10% 50V
C8	0160-3874	2		C Fxd 0.01uF
J2	1200-0926	6	4	5 Pin socket for OP1
J3	1200-0926	6		5 Pin Socket for OP2
J4	1200-0926	6		5 Pin Socket for OP3
J5	1200-0926	6		5 Pin Socket for OP4
L1	9140-0399	7	4	Ind 2.2uH 5%
L2	9140-0399	7		Ind 2.2uH 5%
L3	9140-0399	7		Ind 2.2uH 5%
L4	9140-0399	7		Ind 2.2uH 5%
LK1	1251-4670	2	1	Post, 3 Pin
	1258-0209	9	1	Shorting Link
R1	0757-0459	8	1	R Fxd 56.2K 1% 0.125W
R2	0757-0442	9	2	R Fxd 10K 1% 0.125W
R3	0757-0442	9		R Fxd 10K 1% 0.125W
R4	0757-0438	3	1	R Fxd 5.11K
U1	1820-1423	4	1	ICD 74LS123
U2	1820-1204	9	1	ICD 74LS20
U3	1820-1197	9	1	ICD 74LS00
U4	1820-1430	3	1	ICD 74LS161
U5	1820-1210	7	1	ICD 74LS51

Table 6-4 Replaceable Parts A2 Assembly (Continued)

Reference Designator	HP Part Number	C D	Qty	Description
U6	1820-1196	8	1	ICD 74LS174
U7	1820-1144	6	1	ICD 74LS02
W1	8120-4738	0	1	Ribbon Cable 14 Way
<p>The following 37204A Main List parts are required for options 001/002. These parts are not included in the 37204-60002 Assembly.</p>				
MP8	0515-0536	0	3	Screw M3 X 6
MP9	37204-00017	8	1	Spacer
MP10	0520-0129	8	4	Screw 2-56 X 0.312
MP11	2190-0103	9	4	Washer Lk Int No 2
<p>For Option 002 increase quantity of MP10 and MP11 to 8</p>				
OP1	1005-0021	8		Fiber Optic TX (Port B)
OP2	1005-0005	8		Fiber Optic RX (Port B)
OP3	1005-0021	8		Fiber Optic TX (Port A)
OP4	1005-0005	8		Fiber Optic RX (Port A)

Table 6-5 Replaceable Parts A10 Assembly

Reference Designator	HP Part Number	C D	Qty	Description
A2	37204-60010	7	1	Extended Power Fail Assembly
C1	0180-2207	5	1	C Fxd 100uF 10V TA
C2	0160-4835	7	4	C Fxd 0.1uF 10% 50V
C3	0160-4835	7		C Fxd 0.1uF 10% 50V
C4	0160-4835	7		C Fxd 0.1uF 10% 50V
C5	0160-4835	7		C Fxd 0.1uF 10% 50V
R1	0698-0083	8	3	R Fxd 1.96K ohm 1% 0.125W
R2	0698-0083	8		R Fxd 1.96K ohm 1% 0.125W
R3	0757-0465	6	1	R Fxd 100K ohm 1% 0.125W
R4	0698-0083	8		R Fxd 1.96K ohm 1% 0.125W
R5	0757-0346	2	1	R Fxd 10 ohm 1% 0.125W
R6	0698-3136	8	1	R Fx 17.8K ohm 1% 0.125W
R7	0757-0442	9	1	R Fxd 10K ohm 1% 0.125W
R8	0698-3153	9	1	R Fxd 3.83K ohm 1% 0.125W
R9	0698-3162	0	1	R Fxd 46.4K ohm 1% 0.125W
U1	1826-0175	3	1	ICL 319N
U2	1820-0535	7	1	ICD 75451
U3	1820-3673	0	1	ICD 74HC123
W1	8120-4738	3	1	Ribbon Cable 14 way
<p>The following 37204A Main List parts are required for option 010. These parts are not included in the 37204-60010 Assembly.</p>				
MP8	0515-0536	0	3	Screw M3 X 6



Manual Changes

7-1 Introduction

This section normally contains information for adapting this manual to instruments for which the manual content does not apply directly. Since this manual does apply directly to instruments having Serial Numbers listed on the title page, no change information is given here.

Refer to para entitled SERIAL NUMBER/MANUAL CHANGES in section 1 for additional important information about Serial Numbers coverage.



Service

8-1 Introduction

This section provides fault isolation, service and repair information for the 37204A/B HP-IB Extender.

8-2 Preventive Maintenance

There is no specific preventive maintenance procedure for the 37204A/B. However, if the cable link between Extenders passes through areas of poor environmental condition, check the cable, etc, periodically for damage.

8-3 Fault Isolation

Start with General Service Sheet G1:

1. Use G1-1 to resolve if the problem is caused by an HP-IB device connected to the Extender chain or lies within the 37204A/B Extender chain itself.
2. Use G1-2 to find out which item in the Extender chain is faulty: Extender or cable link.

Use G2-1 to find out which assembly is faulty on the Extender; and, when this is resolved, use A1, A2 or A10 sheets to find the faulty component.

8-4 Safety Requirements

This section contains information and warnings which must be followed for your protection and to avoid damage to the equipment.

WARNING

PROCEDURES DESCRIBED IN THIS SECTION ARE PERFORMED WITH PROTECTIVE COVERS REMOVED AND POWER SUPPLIED TO THE INSTRUMENT. SERVICING SHOULD ONLY BE PERFORMED BY TRAINED PERSONNEL WHO ARE AWARE OF THE HAZARDS INVOLVED.

8-5 Recommended Test Equipment

Test equipment required to maintain the 37204A/B is listed in Table 1-1. Any equipment that satisfies the critical specifications given in the table may be substituted for the recommended models.

8-6 Repair

Once a faulty 37204A/B has been identified, you can choose to repair it to component level or simply replace the failing assembly.

For assembly level repair, refer to General Service Sheet G2. For component level repair, refer to the appropriate Assembly Service Sheet (A1, A2 or A10).

8-7 Co-Axial Cable Repair

Repair damaged or faulty co-axial cable links between Extenders by cutting out the damaged portion of cable and splicing in a new section.

8-8 Fiber Optic Cable Repair

You require special tools to repair fiber optic cable. (HP Part No. HFBR-0100 is a

complete tooling kit including connectors and consumables.) If you do not wish to repair a cable yourself, ask your nearest Hewlett Packard Service office for assistance.

Ensure that the ferrule tip of the fiber optic cable and the fiber optic connector are kept clean. Fit protective covers over any unused connectors. If the connector ferrule becomes dirty, wipe it clean with a swab moistened with iso-propyl alcohol.

8-9 Description Of Self Test

8-9-1 Introduction

Self test runs a thorough check on Extender performance and also provides signals used in troubleshooting. Figure 8-1 shows all the functional blocks and signal paths involved in self test.

Self test forces U10 to exercise and check all signal paths which carry either HP-IB data or serial message frames. Correct self test operation is indicated by both PORT FAULT lamps flashing on briefly at power-on, then remaining off. Subsequent lighting of a PORT FAULT lamp indicates a self test failure. A fault lamp may remain lit even after the fault has disappeared or been removed. Recycling power resets self test.

8-9-2 Co-Axial Ports

U10 outputs serial data frames to the A and B port alternately. The loop-backs built into the co-axial ports (loop-backs 1 and 2 in Figure 8-1) return the message frames to U10. Any received data errors or absence of looped-back data cause self test to fail. If a port fails, U10 transmits continuously to the failing port until a good message is received and no message frames get sent to the other port.

The serial message frames sent to each port are approximately 2us long and repeated every 15us in NORMAL speed (20us long, repeated every 150us in SLOW speed).

8-9-3 HP-IB Interface

The HP-IB output lines from U10 are looped back to U10 via the driver/receiver pairs of transceivers U1 through U4 (loop-back paths 3 through 18 in Figure 8-1). The message frames used to test the co-axial ports also exercise all active HP-IB interface lines, driving these lines high and low. The user must check both co-axial loop-back paths before checking the HP-IB interface lines.

A fault in one of the transceiver loop-back paths may cause other HP-IB interface lines from U10 to stay stuck at either a high or a low level. For this reason, the user must check HP-IB loop-back paths in the order shown in Figure 8-1 because the first stuck loop-back path identifies the faulty path.

8-9-4 Fiber Optic

The co-axial ports must pass self test before the user can test the fiber optic ports.

For self test of a fiber optic port, the user sets the rear panel switch to FIBER, connects the fibers optic transmitter to receiver via an external looping cable and recycles power. The fiber optic loops are 1f and 2f in Figure 8-1.

Note: The duration of the lamp flash (which indicates a pass) is longer when one or more fiber ports are selected - approximately 2.6s.

8-10 Running Self Test

Self test exercises all the main functions of the 37204A/B including co-axial, fiber optic and HP-IB interfaces.

8-10-1 Testing the COAX Ports

1. Disconnect the Extender from the Extender network. On the rear panel, set the TEST switch to TEST and the FIBER switches to NORMAL.
2. Apply power. Check that the front panel POWER lamp lights. If not, check the internal line fuse. See Appendix A for voltage selection/fuse information.
3. Recycle power on the 37204A/B. Check that both PORT FAULT lamps flash on briefly then remain off.

37204A: Both PORT FAULT lamps flash almost immediately after power is re-applied.

37204B: There is a distinct pause, 1.5s long, after power is re-applied before the PORT FAULT LAMPS flash. If the lamps flash but the pause is substantially longer or shorter than 1.5s, suspect the Extended Power Fail Assembly (A10).

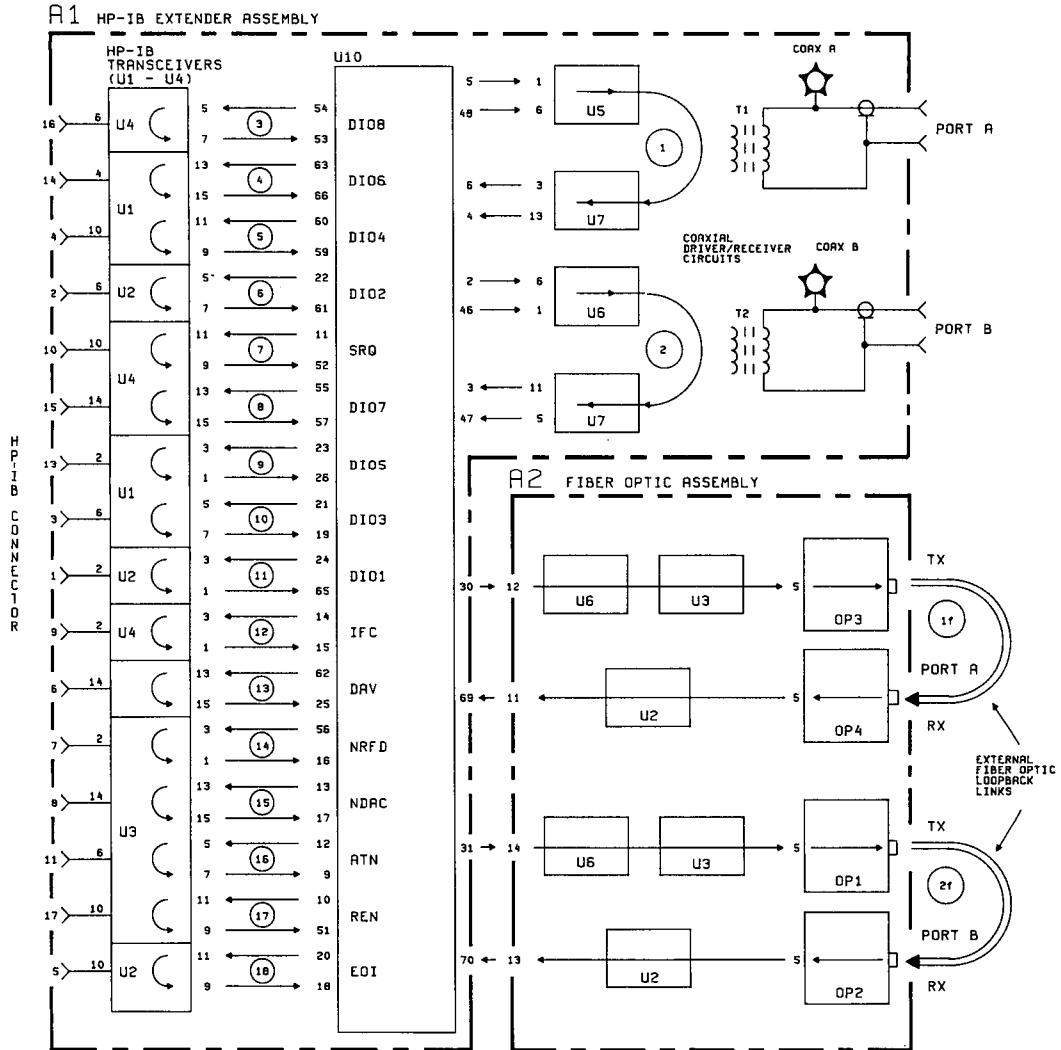

Figure 8-1 Block Diagram of 37204A Showing Self Test Loop-back Paths

4. If either PORT FAULT lamp does not flash, flashes after the initial turn-on flash, or remains on, suspect the A1 assembly.
5. On Extenders without fiber optic ports, self test is complete. Reset the TEST switch to NORMAL.

8-10-2 Testing The Fiber Optic Ports (Option 001/002 Only)

1. Set the rear panel switch to FIBER on the port under test. If the Extender has two fiber ports, set the other port to NORMAL.
2. Connect a fiber optic loop-back cable between TX and RX on the selected fiber optic port. (A plastic fiber loop-back cable, HP Part No. 5061-2964 is suitable. The cable fits inside the inner sleeve of the fiber optic port. Make sure it is pushed fully home.)
3. Recycle power. Check that both PORT FAULT lamps light for about 2.5s, then go off, and remain off. If either lamp fails to come on, remains on, or flashes again, suspect the fiber optic port under test.
4. If the Extender has a second fiber optic port, reset the rear panel FIBER switches: port just tested to NORMAL; port not tested to FIBER. Repeat from step 2.
5. Reset the TEST switch to NORMAL and the FIBER switches to their original states.

GENERAL SERVICE SHEET G1

SYSTEM TROUBLESHOOTING

G1-1 Faulty Extender Chain or HP-IB Device?

This procedure will help you determine if the problem is within the Extender chain or caused by a device connected to the Extender chain.

Note: Sometimes HP-IB/IEEE 488 devices work correctly when directly connected but not when linked via 37204A/B Extenders. Do not assume that the problem is caused by the Extender chain. It could well be poor implementation of the IEEE 488-1978 standard in one of the devices connected to the Extender chain.

G1-1-1 All PORT FAULT lamps Off

In this case, communication between Extenders is OK but the HP-IB interface on an Extender could be faulty. To check, run self test (para 8-10) on all Extenders.

G1-1-2 One or More PORT FAULT Lamps On

1. *Truncation feature not enabled.* In this case, look no further than the master Extender. If a lamp is on or flashing, suspect a fault in the Extender chain and proceed to para G1-2.
2. *Truncation feature enabled on all Extenders.* Locate the truncating Extender (Figure G1-1):
 - Extenders from the master up to (but not including) the truncating Extenders have all PORT FAULT lamps off.
 - The truncating Extender and the end Extender have one PORT FAULT lamp on and the other off.
 - Extenders beyond the truncating Extender up to the end Extender have all PORT FAULT lamps on.

Run self test (para 8-10) on the truncating Extender and its neighbor nearest to the end Extender. If both Extenders pass, suspect the cable link between the Extenders. If either Extender fails, proceed to para G2-1.

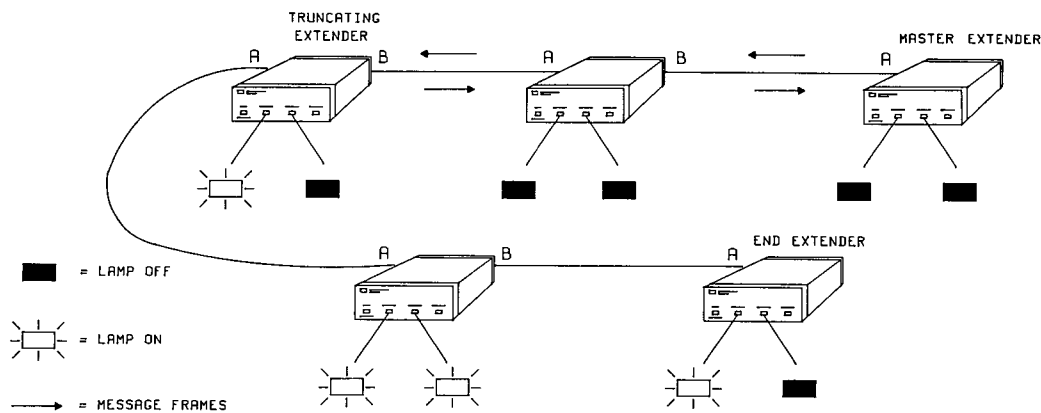

Figure G1-1 Locating a Truncating Extender

G1-2 Troubleshooting Within The Extender Chain

G1-2-1 Background

In an Extender chain, message frames propagate from the master Extender along the Extender chain to the end Extender, then return in the reverse direction to the master. Only one message frame is allowed in the Extender chain at any one time: the master Extender waits until the frame is returned before generating a new frame. *The message path is thus a loop, beginning and ending at the master.*

If no message is returned within the master's timeout period, the master lights its PORT A FAULT lamp and re-transmits the original message. The PORT A FAULT lamp will remain on until message frames are again received back at the master. Non-return of a message frame indicates that the message frame has been lost. There are two possible causes:

1. There is a break in the message path, for example, faulty Extender, incorrectly set POSITION switches on the Extenders, a powered-down Extender, or a broken cable between Extenders.

2. A message frame has been corrupted in transmission and rejected by the receiving Extender, so that no frame is forwarded to the next Extender.

The status of the PORT FAULT lamps on the remaining Extenders indicates the location of the fault in the system. On these Extenders, a PORT FAULT lamp lights if,

1. No message frames have been received at that port for 100ms.
2. A corrupted message frame has been received.

The master timeout (1.6ms) is much shorter than the 100ms timeout of the other Extenders in the chain. Thus, Extender ports located before a break in the chain receive a message frame every 1.6ms and have their PORT FAULT lamps off, whilst Extender ports located after the break will have their PORT FAULT lamps on.

If an occasional message frame is corrupted, the master PORT A FAULT lamp flashes (no frame returned) and the PORT FAULT lamp on the Extender receiving the faulty message frame also flashes. Other port fault lamps in the chain may remain off. See Figure G1-2.

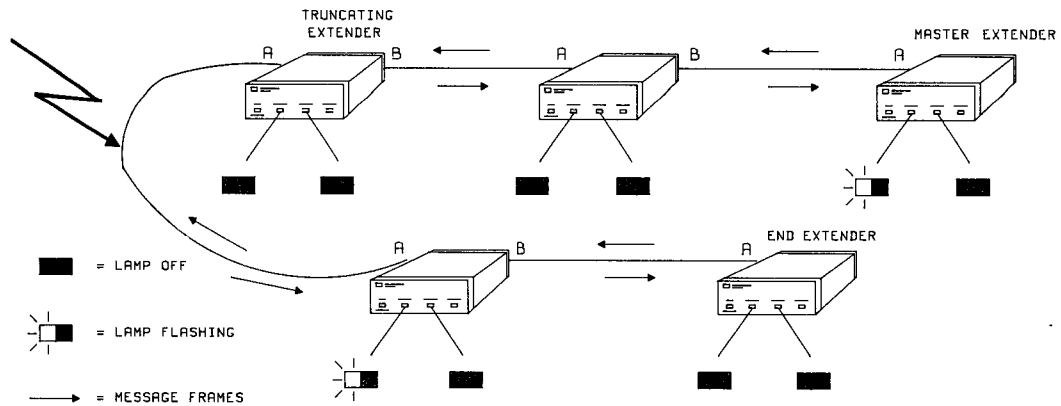

Figure G1-2 PORT FAULT Lamp Indications caused by Intermittent Errors

G1-2-2 Locating The Faulty Extender or Cable Link

Procedure:

1. Disconnect the system controller and all HP-IB devices from the Extender chain. Recycle power on all Extenders.

Note: Step 1 is essential if the truncation feature is enabled: by preventing the system controller from asserting IFC, truncation cannot be initiated. Recycling power clears any existing truncation.

2. Determine for each Extender which port (A or B) runs back towards the master Extender and which runs out towards the end Extender.
3. Refer to Figure G1-3. Working out in strict order from the master (which should have PORT A FAULT lamp on or flashing), check the status, on each Extender, of the port running back to the master.
 - If the PORT FAULT lamp is off, move on to the next Extender. (For the moment (ie until step 5), ignore the status of the other PORT FAULT lamp.)
 - If the PORT FAULT lamp is on or flashing, go to step 4.
4. A PORT FAULT lamp lit indicates that communication is broken between the present Extender and the previous Extender visited. (A flashing PORT FAULT lamp indicates occasionally missing or corrupted message frames.) Suspect either of the Extenders or the cable link between the Extenders. To determine which, run self test (para 8-10) on the two Extenders. If both pass, suspect the cable link.
5. If the steps taken so far have not isolated the fault, use the same procedure but work back from the end Extender. This ensures that the complete loop which frames have to take is checked out and is particularly important for fiber optic links where the go/return paths are separate.

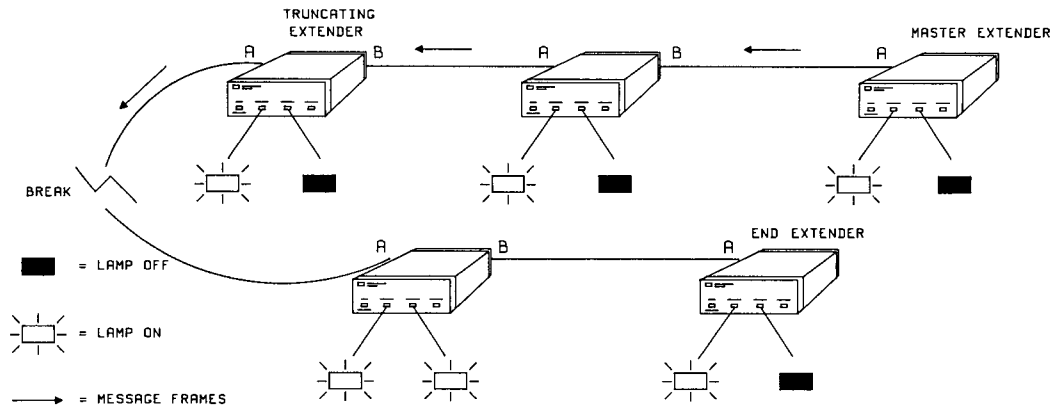

Figure G1-3 PORT FAULT Lamp Indications caused by a Continuous Failure



GENERAL SERVICE SHEET G2

INSTRUMENT TROUBLESHOOTING

G2-1 Determining Which Assembly is Faulty

Use this procedure for on-site repair of a faulty 37204A/B when component level troubleshooting and repair procedures are not practical, or as a first step in component level troubleshooting on a particular assembly.

The 37204A/B is configured according to model and option as follows:

Model	Assemblies fitted
37204A	A1
37204A Option 001	A1 + A2
37204A Option 002	A1 + A2
37204B	A1 + A10

Procedure:

1. Run the 37204A/B self test (para 8-10) and note at which stage the test fails.
2. If self test fails at para 8-10-1 and A10 is fitted and suspected as possibly faulty, proceed to step 5. However, if A10 is not fitted or A1 is clearly faulty, replace A1 as described in para G2-2.
3. If a 37204A option 001/002 fails self test at para 8-10-2, suspect the A2 fiber optic assembly. Since it is not reckoned economic to replace a complete A2 assembly, further fault isolation is recommended (step 4).
4. The A2 Fiber Optic Assembly comprises the parts listed in Table G2-1. Identify the faulty module by substituting a known good part and re-running self test after each substitution.

Note: The fiber optic transmitter and receiver modules plug into sockets on the A2 Assembly and are retained in position by screws through the underside of the pc board. Leads on a replacement fiber optic module may have to be trimmed back to fit into the socket. Use the original part to determine the correct length.

Table G2-1 A2 Fiber Optic Assembly: Field Replaceable Parts

Field Replaceable Part	Part Number	Option 001 QTY	Option 002 Qty
Option PC Board	37204-60001	1	1
Fiber Optic Transmitter	1005-0021	1	2
Fiber Optic Receiver	1005-0005	1	2

5. If self test clearly indicates a failure of the A10 assembly, replace A10. Otherwise, disconnect the ribbon cable from A10 assembly to A1 assembly and re-run self test. If self test passes, A10 assembly is faulty. If self test fails, A1 assembly is faulty. Replace A1 assembly as described in para G2-2.

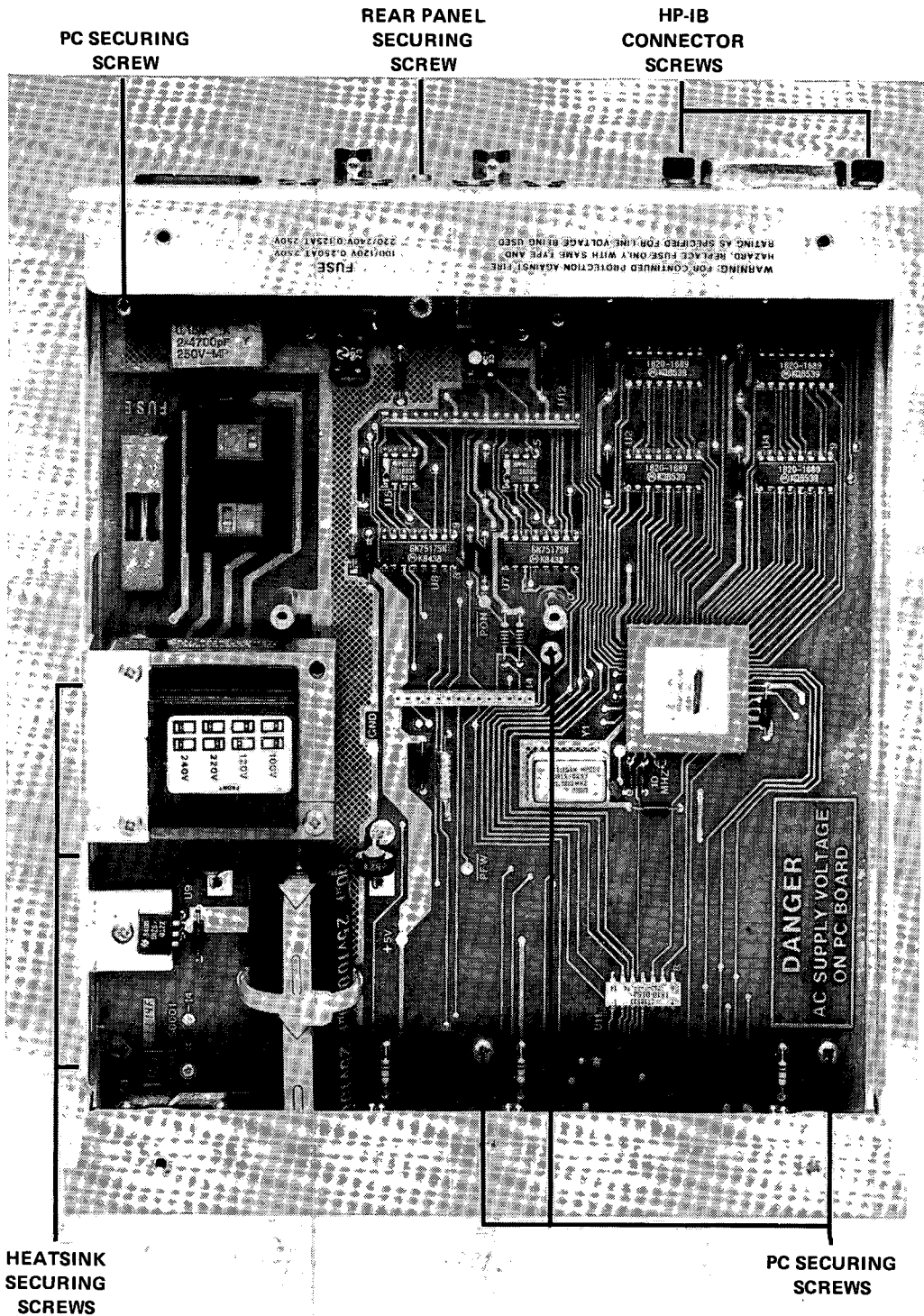

Figure G2-1 Assembly Retaining Screws

G2-2 A1 Assembly Replacement Procedure

The 37204A and 37204B HP-IB Extenders use a common A1 assembly which is available either as a new or exchange part.

	New Part Number	Exchange Part Number
HP-IB Extender Assembly	37204-60001	37204-69001

Procedure:

1. Disconnect all cabling to the Extender.
2. Remove the plastic trim from the front and rear panels. Release the trim by pushing outwards on one of the sides and the sliding trim forward. See Figure B-1, Appendix B.
3. Undo 8 cross-head screws and remove the top cover.
4. Remove the Fiber Optic (A2) assembly or Extended Power Fail (A10) assembly from A1 and retain for re-fitting onto the replacement A1 assembly.
5. Remove the 2 screws securing the HP-IB connector to the rear panel. Undo 1 cross-head screw securing the A1 assembly to the rear panel.
6. Disconnect the safety earth from the power cord socket to the rear panel.
7. Remove 3 screws securing the heatsink to the left-hand side of the Extender.
9. Undo 4 screws and remove A1 assembly from the bottom cover.

Replacement is the reverse of disassembly. Ensure that:

1. The two voltage selection switches on the replacement board are set for the correct voltage, and that the fuse is of the correct value (use the fuse from the original board if necessary). Refer to Appendix B for information on voltage selection.
2. Replace the top cover with the magnetic shield positioned over the power supply transformer.

ASSEMBLY SERVICE SHEET A1

HP-IB EXTENDER MAIN ASSEMBLY

A1-1 Introduction

This service sheet provides component level repair information for A1 assembly. The schematic diagrams for the power supply and the Extender logic are provided on separate sheets.

A1-2 Circuit Description

Regulator U9 produces +5V. If the unregulated supply to U9 falls below 7.7V, the POWER FAIL signal at U8(3) and the POWER-ON signal at U8(5) are pulled low.

The RESET signal to U8(6) is an input from the optional Extended Power Fail assembly A10. When this line is pulled low during an extended reset, the POWER-ON signal is pulled low forcing the DISABLE HP-IB DRIVERS signal at U8(11) high.

All the logical functions of the HP-IB Extender are performed within U10 which obtains timing from the 30MHz oscillator Y1. Transceivers U1 through U4 provide buffering between U10 and the HP-IB signals at connector J1.

Since identical driver/receiver circuits interface U10 with the A and B co-axial ports, only Port A circuit is described here.

The co-axial port uses alternate mark inversion (AMI) encoding (i.e "1's" are sent alternately as positive and negative going pulses). Separate open collector drivers (U5) driven by U10(48) and U10(5) provide the +ve and -ve drive through transformer T1 which isolates the co-axial port from its driver/receiver. The co-axial shield is isolated from ground and allowed to float. However, varistor CR3 limits the maximum voltage on the co-ax shield to 24V.

Signals received from the co-axial port are detected using a pair of comparators (U7), one for each direction of received signal swing (+ve or -ve). The outputs from the comparators are taken directly to U10(4) and U10(6). Typically, with no signal input, the voltages at the + and - inputs of comparator U7 are 4.7V and 4.0V, respectively.

Connector J5 links A1 to the A2 Fiber Optic or A10 Extended Power Fail assemblies. Edge connector J3 is used during production test and has no other function.

A1-3 Troubleshooting Procedure

Enter this procedure after running self test (para 8-10) and failing the COAX ports test (para 8-10-1).

General:

1. If an Extended Power Fail (A10) or Fiber Optic (A2) assembly is fitted, disconnect the ribbon cable at J1. It may be convenient to remove the A2 or A10 assembly.
2. Set all rear panel switches to NORMAL (down). Set the front panel POSITION switch to MASTER. Power on the Extender.
3. Check that the voltage on the +5V test pin is $+5V \pm 0.25V$. Check that the power supply ripple is less than 50mV peak-to-peak.
4. Check that the $\overline{\text{PFW}}$ (Power Fail Warning) and $\overline{\text{PON}}$ (Power ON) test points are both high.
5. Check that the frequency at the 10MHz test point is $10\text{kHz} \pm 10\text{kHz}$. If correct, the 30MHz output of Y1 can be assumed OK.

Port A:

6. Check at the COAX A test point for a short (approximately 2us) burst of AMI signal occurring every 1.6ms. The signal waveform has the form

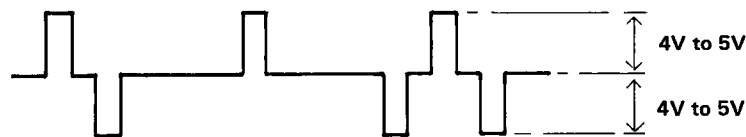

- If the signal is OK, check that U10 is receiving data by looking for bursts of TTL

activity at both U7(3) and U7(13). If this is OK, suspect U10, otherwise suspect the comparator circuit (U7).

- If the signal pulses are of only one polarity, suspect one of the output drivers (U5) or U10. Confirm this by looking for TTL activity at U5 (6,7) and U5 (1,2).
- If no signal is present, suspect a discontinuity in the driver output circuitry (U5 and T1). Also check that MASTER mode is selected correctly on S1.

Port B:

7. If step 6 shows correct operation at port A, set the rear panel TEST switch to TEST, recycle power and check out port B in a similar manner to port A. (Look for inputs to U10 at U7(11) and U7(5) and outputs from U10 at U6(1,2) and U6(6,7).)

Note: Self test sends out data alternately to ports A and B when no fault is found but continuously to one port when found faulty. Thus, if port A passes and port B fails, nothing gets sent again to port A until port B passes; and if port A fails, nothing gets sent to port B.

8. If the A and B ports pass self test, set the front panel switch to MIDDLE and check that the AMI signal is switched off at the COAX A test point. If not, suspect S1 or U10.

HP-IB Interface:

9. Self test exercises, continuously and in a set sequence, all the HP-IB interface lines on U10. Transceivers, U1 through U4, output the signals from U10 to the HP-IB connector (J1) and, at the same time, loop them back to U10. Using an oscilloscope or logic probe, check the operation of the HP-IB lines by looking for TTL activity on all the pins listed in Table A1-1. Work down from the top of the table in strict order.

Note: 1. The paths through the transceivers are non inverting. If an output from U10 is found to be stuck, check that the transceiver returns the same TTL level to U10 as sent out. If not, suspect the transceiver; otherwise suspect U10.

2. **The HP-IB handshake lines DAV, NRFD and NDAC and ATN have to be considered together. If any one is found to be stuck, check the transceivers in all three handshake lines and ATN as described in Note 1 before suspecting U10.**

Table A1-1 U10 HP-IB Loop-back Testing Sequence

O/P from U10	Connection to HP-IB Bus	I/P to U10	Interface Signal
U4 (8)	U4 (6)	U4 (7)	DIO 8
U1 (13)	U1 (14)	U1 (18)	DIO 6
U1 (11)	U1 (10)	U1 (9)	DIO 4
U2 (8)	U2 (6)	U2 (7)	DIO 2
U4 (11)	U4 (10)	U4 (9)	SRQ
U4 (13)	U4 (14)	U4 (18)	DIO 7
U1 (3)	U1 (2)	U1 (1)	DIO 8
U1 (8)	U1 (6)	U1 (7)	DIO 3
U2 (3)	U2 (2)	U2 (1)	DIO 1
U4 (3)	U4 (2)	U4 (1)	IFC
U2 (13)	U2 (14)	U2 (18)	DAV
U3 (3)	U3 (2)	U3 (1)	NRFD
U3 (13)	U3 (14)	U3 (18)	NDAC
U3 (8)	U3 (6)	U3 (7)	ATN
U3 (11)	U3 (10)	U3 (9)	REN
U2 (11)	U2 (10)	U2(9)	EOI

19. If the above checks do not pinpoint the problem, replace U10 and repeat self test. U10 is installed in a socket and may be removed by gently easing up each side of U10 in turn with a small flat bladed screwdriver.



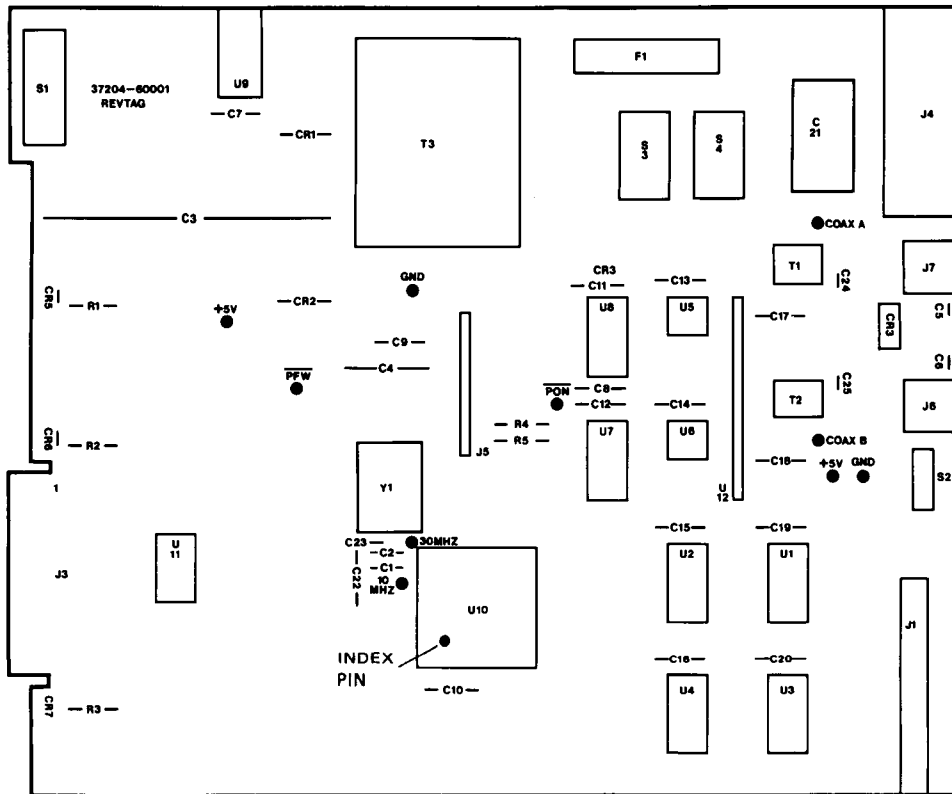

Figure A1-1 A1 Component Location

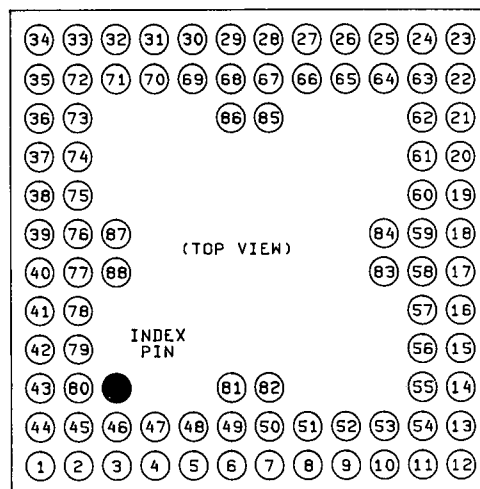
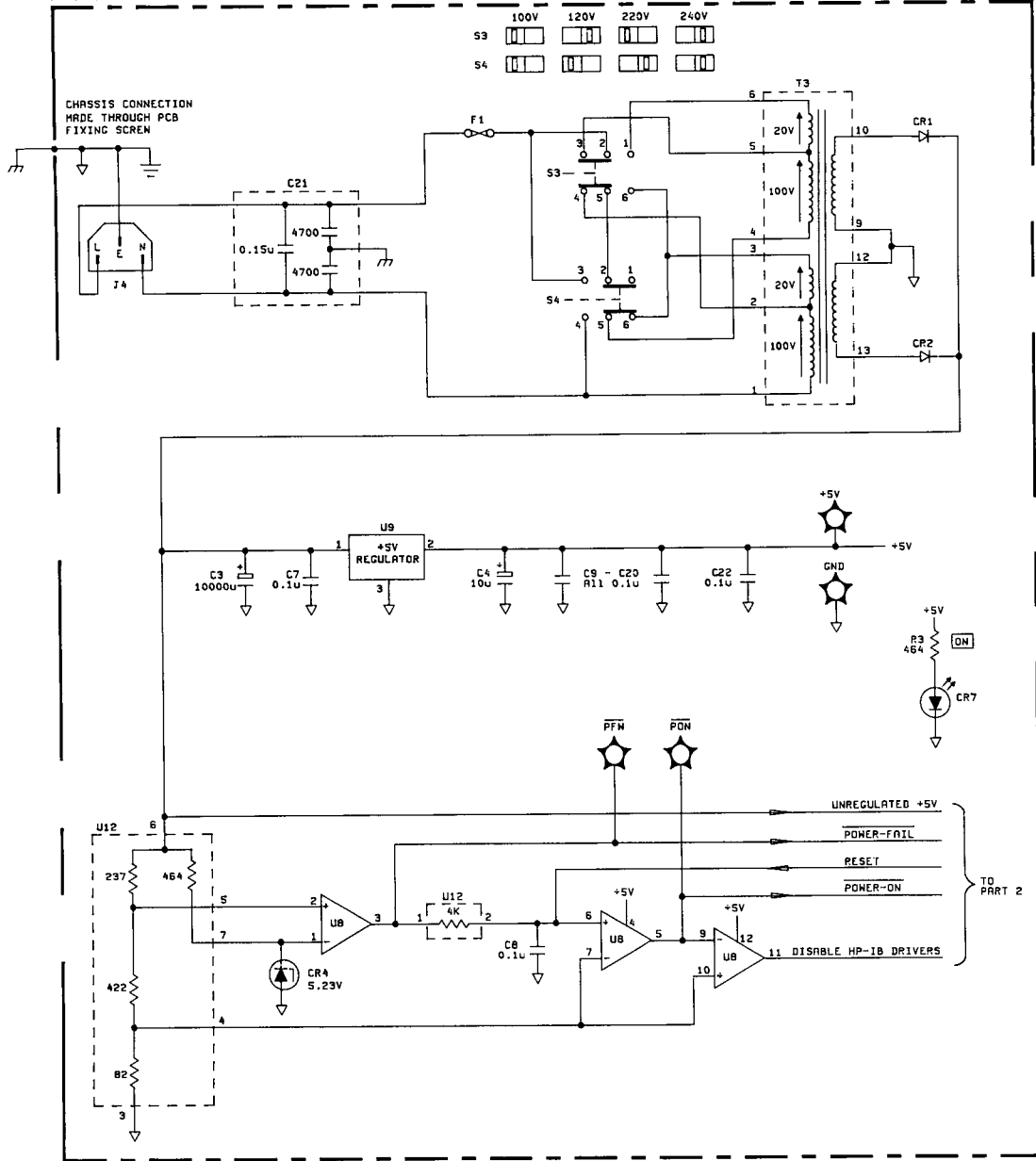

Figure A1-2 U10 Pin Location

A1 HP-IB EXTENDER ASSEMBLY (PART 1) 37204-60001



A1-3 A1 Power Supply

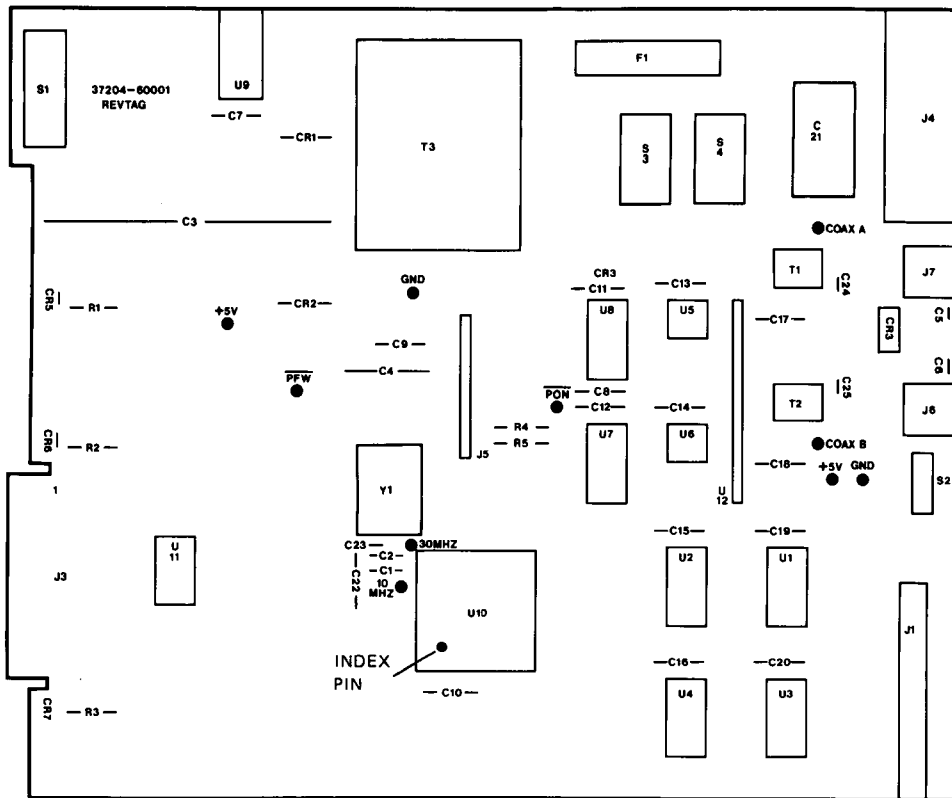

Figure A1-4 A1 Component Location

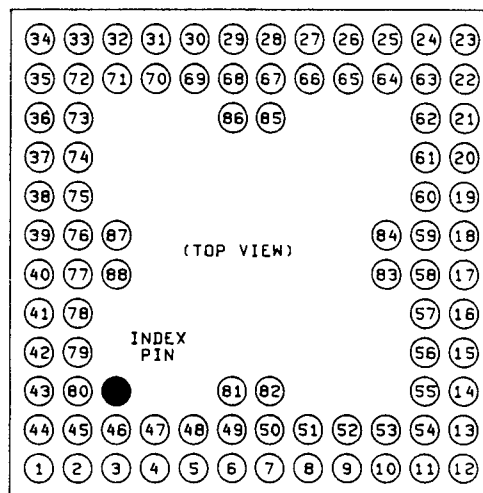

Figure A1-5 U10 Pin Location



Figure A1-6 A1 Extender Logic and Driver/Receivers



ASSEMBLY SERVICE SHEET A2

FIBER OPTIC ASSEMBLY

A2-1 Introduction

This service sheet provides component level repair information for the A2 assembly. The assembly may have one (option 001) or two (option 002) fiber optic ports fitted.

A2-2 Circuit Description

Separate, plug-in, fiber optic modules provide the fiber/electrical conversion on A2 Assembly (2 transmitter and 2 receiver modules).

The setting of the FIBER switches on the rear panel determines which or both of the transmit/receive signal pairs are routed from A1 to A2 assemblies.

Since ports A and B have identical transmit/receive circuits, only port A circuit is described here.

The transmit signals arriving at J1(12) are delayed by two clock pulses (via two D-type flip flops in tandem) and inverted before being input at pin 5 of the fiber optic transmitter.

The MONITOR output (pin 2) of a fiber optic receiver goes low if the received light level falls below a safe level. The signal is gated with the received signal (U2 pin 10) to disable the received signal line if the MONITOR output goes low. However, the MONITOR output may take up to 2s to react to a sudden drop in the light level. During this period, random data could be output by the fiber optic receiver. An interlock prevents this from being interpreted as valid data. Whenever a corrupted data frame is detected by A1 U10, FRAME BLANK TRIGGER triggers monostable U1A which disables the received data path in U2 for 2.6s, allowing sufficient time for the MONITOR line to go low.

The remaining circuitry on the A2 assembly ensures that pin 1 (MODE) on the fiber optic transmitter modules is correctly conditioned. Different conditioning sequences are used for SLOW and NORMAL speeds.

In SLOW speed, monostable U1B is enabled and is continuously triggered at the 1MHz by CLK. The output from the monostable is a continuous train of short-duration, high-going, 1MHz pulses which are applied to the MODE input of the fiber optic transmitters.

In NORMAL speed, the MODE input is pulsed high immediately before the start of each 22-bits-long message frame. This is achieved as follows.

The low-going start pulse at the beginning of each message frame is detected at U5(3) or U5(2) which forces U5(6), and, in turn, MODE on the fiber optic transmitters, to go high. The start pulse also triggers the COUNT 25 LOGIC by setting U5(8) high. Once U6 is clocked, the high at U5(8) is transferred to pin 9 (LOAD) of the binary counter U4 allowing it to count up.

The high at U6(12) forces U5(6) (and thence MODE) low again. MODE remains low until U6(12) returns to low 25 clock pulses later. Since the message frame is 22 bits long, MODE is not pulsed again until the start of the next message frame.

Link LK1 is used during factory tests to determine the option status of the 37204A/B under test. The setting of this link has no effect on Extender operation and can be ignored.

A2-3 Troubleshooting Procedure

Enter this procedure after running self test (para 8-10), passing the COAX port tests (para 8-10-1) but failing the fiber optic port tests (para 8-10-2).

Data Path Through Fiber Ports:

1. Set the rear panel switch to FIBER on the port failing self test and to NORMAL on the other port. If both fiber ports fail self test, select PORT A and test first; then select PORT B and repeat the tests.
2. Set the rear panel TEST and SLOW switches up and set all other switches to NORMAL. Using optical cable, loop the transmitter to the receiver on the port under test (see para 8-10-2). Recycle power.
3. Use table A2-1 to check the data paths through ports A and B.

Table A2-1 Looped Back Test Signals

Signal	Test Point (Port A)	Test Point (Port B)	Correct Test Signal
1	TX (FIBER A)	TX (FIBER B)	TTL activity
2	U6(5)	U6(10)	Signal 1 delayed by 2 clock pulses
3	U3(3)	U3(6)	Signal 2 inverted
4	U2(10)	U2(2)	Signal 3
5	U2(8)	U2(6)	Signal 3 inverted

4. Check that the MODE signal at TP1 is a train of narrow (90ns), high-going pulses at 1MHz. If the signal is missing or wrong, suspect monostable U1B.
5. Recycle power and check that the monostable output at U1(12) is held low for approximately 2.6s after power is applied, then goes high and remains high. If the monostable gets triggered (output low) after the initial 2.6s, AIU10 is detecting errors in the received signal. The problem may be a faulty fiber optic transmitter or receiver module.

Count 25 Logic:

6. The Count 25 logic is enabled when $\overline{\text{SLOW}}$ is active (i.e. J1(4) high). To check the logic, set the rear panel SLOW switch to NORMAL and recycle power. (The optical loop back is not needed for this test and may be removed).
7. Check TP1 for a short high-going pulse (0.2us wide). The pulse should not repeat within 2.5us. If the pulse is missing or otherwise incorrect, set the rear panel TEST switch to NORMAL, the front panel position switch to MIDDLE and recycle power.
8. Check that U5 pins 2, 3, 4, 5, 9, 10, 11 and 12 are all high and that U5 pins 1, 6, 8 and 13 are all low.
9. Reset the rear panel switch to TEST and recycle power.

10. Check that the low-going pulse at the start of each TX message on J1(12) or J1(14) causes a rising edge on U5(6) and U5(8).
11. Trigger an oscilloscope on the rising edge of the signal at U4(9). Check that U4(9) stays high for 2.5us (25 x 1MHz clocks) then goes low. If the signal is incorrect, check the count sequence of U4.



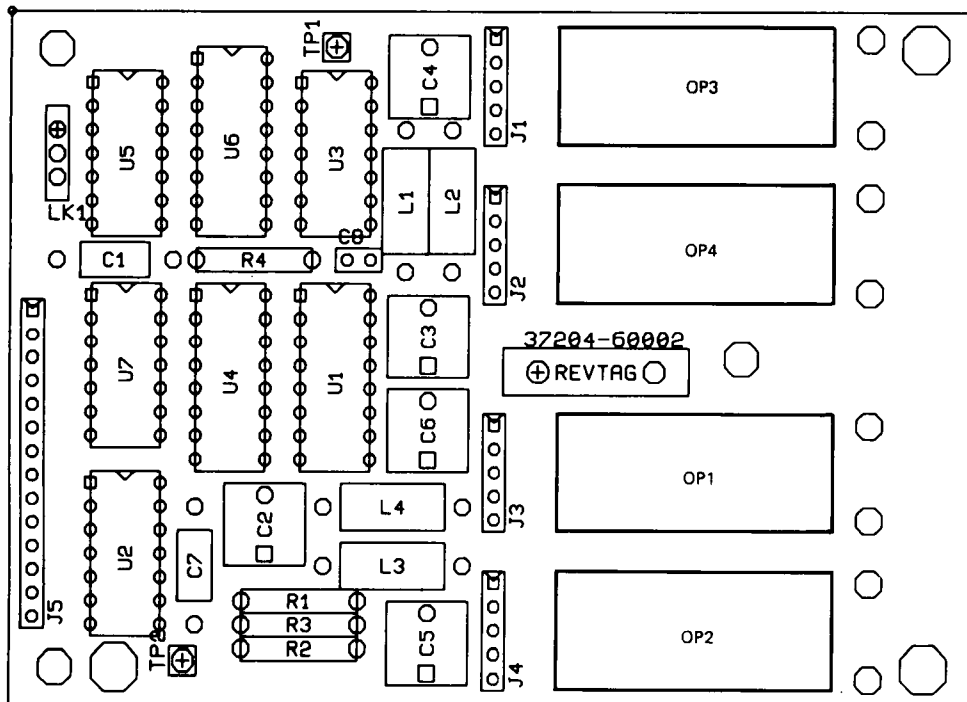
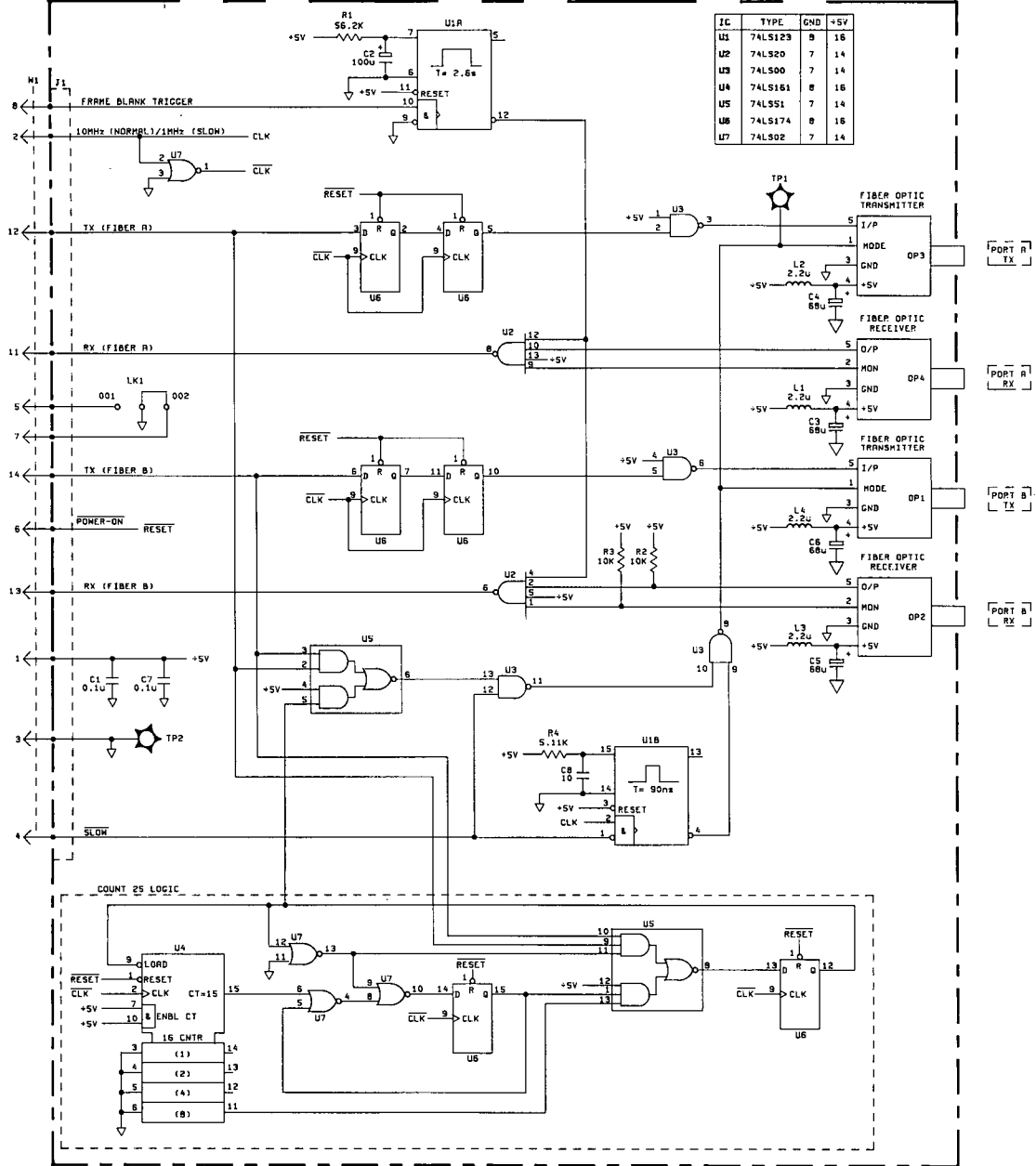

Figure A2-1 A2 Component Location

A2 FIBER OPTIC ASSEMBLY (OPTION 001/2) 37204-60002



IC	TYPE	GND	+5V
U1	74LS123	8	16
U2	74LS20	7	14
U3	74LS00	7	14
U4	74LS161	8	16
U5	74LS51	7	14
U6	74LS174	8	16
U7	74LS02	7	14

A2-2 Fiber Optic Drivers/Receivers

A10 POWER FAIL (37204B) 37204-60010

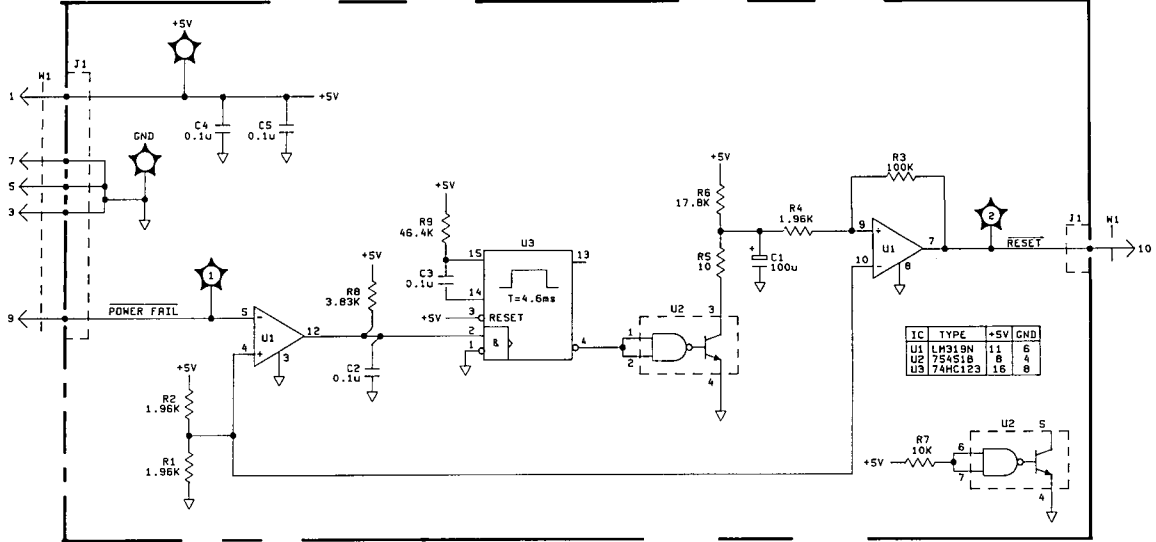

Figure A10-1 Power Fail Timer

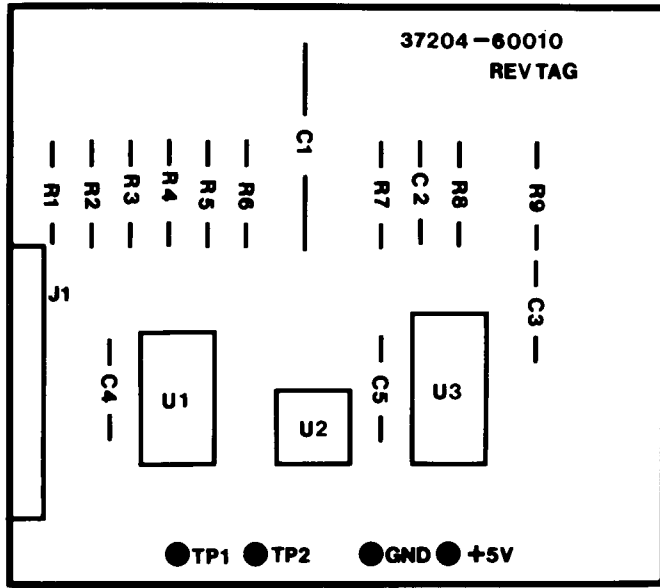

Figure A10-2 A10 Component Location

ASSEMBLY SERVICE SHEET A10

EXTENDED POWER FAIL ASSEMBLY

A10-1 Introduction

This service sheet provides component level repair information for the A10 Assembly.

A10-2 Circuit Description

The Extended Power Fail Reset Assembly (A10) ensures that if a momentary power fail (or brownout) occurs, the RESET signal remains low for between 1s and 2s.

If the signal at TP1 falls below the 2.5V threshold set by R1/R2, monostable U3 is triggered. The resulting low-going pulse at U3(4) discharges C1 through R5. When the monostable returns to its stable state, capacitor C1 recharges through R6. During the recharge period, TP2 is pulled low.

A10-3 Troubleshooting Procedure

1. Check TP1 and TP2 are >3.5V.
2. Momentarily ground TP1 (Power Fail) and check TP2 goes low for between 1 and 2s.

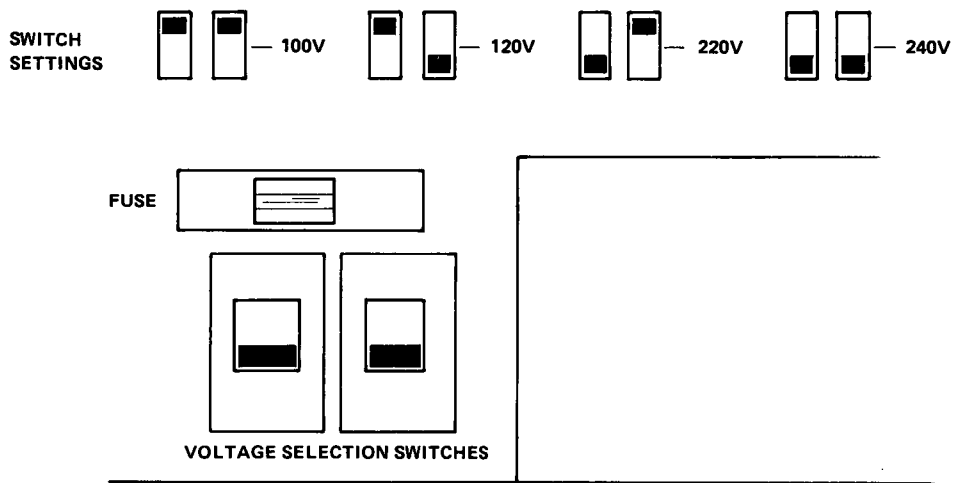

Figure A-1 Line Voltage and Fuse Selection

APPENDIX A

LINE VOLTAGE SELECTION

The ac voltage range of the 37204A/B is internally set by two switches. To change the 37204A/B voltage setting:

1. Disconnect the Extender from the ac power supply.
2. Remove the front and rear panel trims (see Figure B-1).
3. Undo 8 cross-head screws and remove the top cover.
4. Set the voltage select switches as required (see table below and Figure A-1)
5. Replace Fuse F1 with a fuse of the correct rating for the voltage range selected.
6. Mark the new voltage range setting on the rear panel above the power cord socket. You can erase the existing marking by wiping with a clean swab soaked in isopropyl alcohol.

Voltage Setting	Operating Range	Fuse	
		Rating	HP P/N
100V	90/105Vac	250mAT	2110-0201
120V	108/126Vac	250mAT	2110-0201
220V	198/231Vac	125mAT	2110-0318
240V	216/252Vac	125mAT	2110-0318

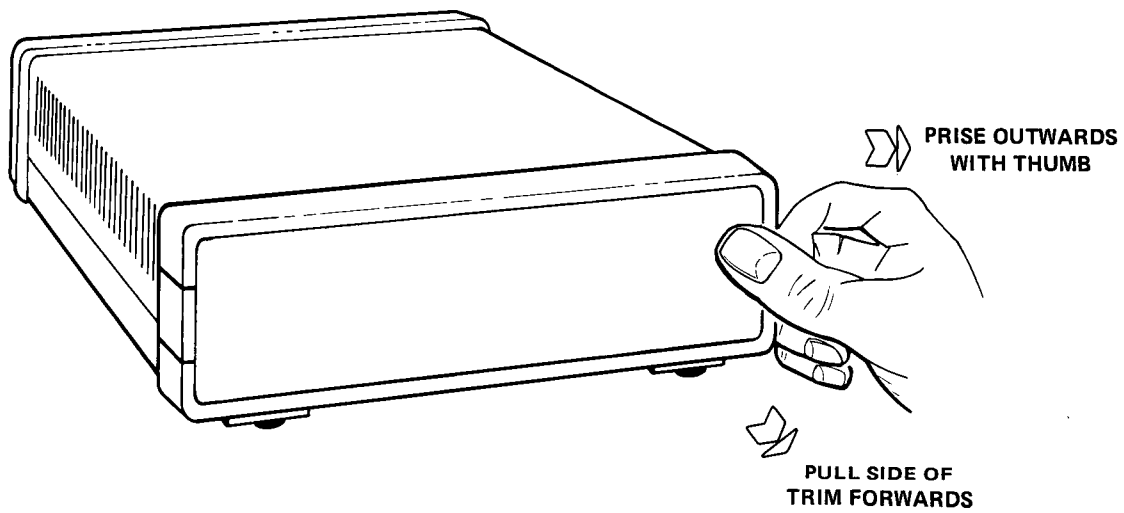

Figure B-1 Removing the Front Panel Trim

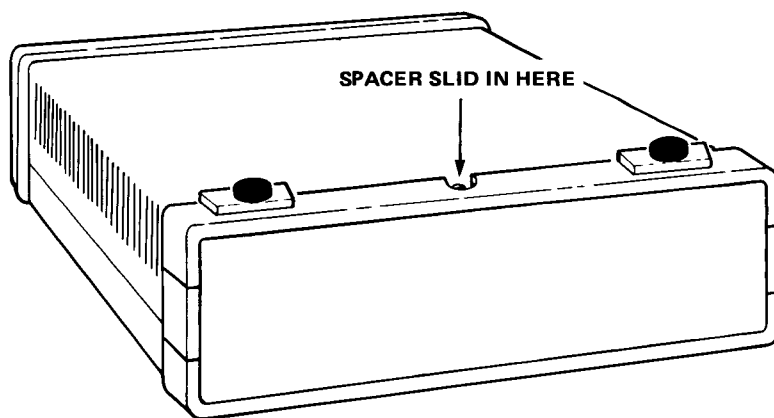

Figure B-2 Inverting the Front Panel Trim

APPENDIX B

RACK MOUNTING

Rack Mounting 37204A/B Extenders

Use kit HP Part No. 5060-4463 to mount one or two 37204A/B Extenders in a standard 19 inch rack. The kit includes a blanking panel in case only one Extender position is used.

Procedure:

1. Remove the plastic trim from the front of the Extender. Release the trim by pushing outwards on one of the sides and sliding the trim forward (Figure B-1).
2. Invert the trim so that the rubber feet are uppermost and replace the trim on the Extender (Figure B-2).
3. Hold the rack mounting panel with the two fixing holes downward and insert the front of the Extender into the cutout. Secure the Extender with two fixing screws through the bottom holes (Figure B-3).
4. Slide the spacer provided into position on the top of the Extender, and secure spacer, Extender and rack mounting panel with a fixing screw (Figure B-3).
5. Repeat for the second Extender or fit the blanking panel supplied into the unused position.
6. Fit the assembly into the rack.

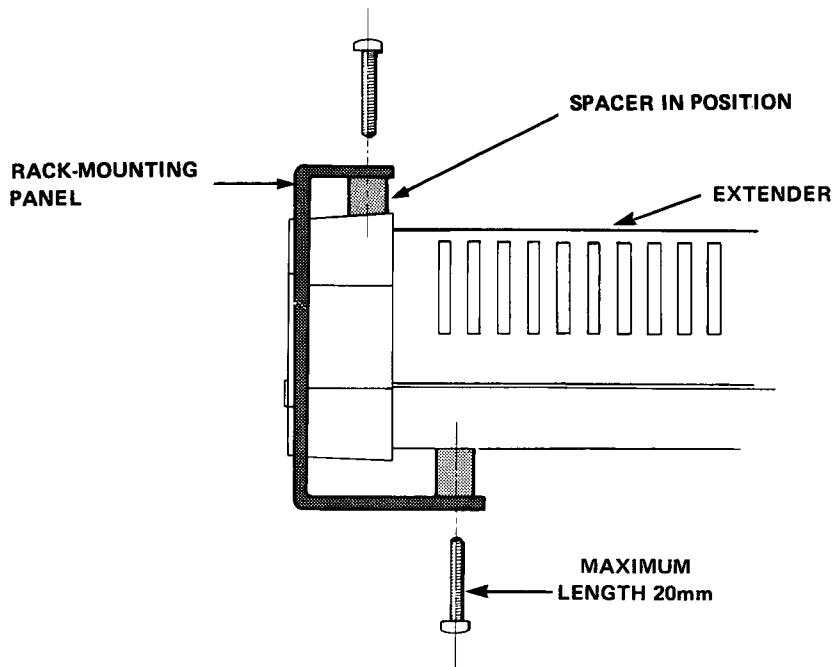

Figure B-3 Mounting in a 19 inch Rack

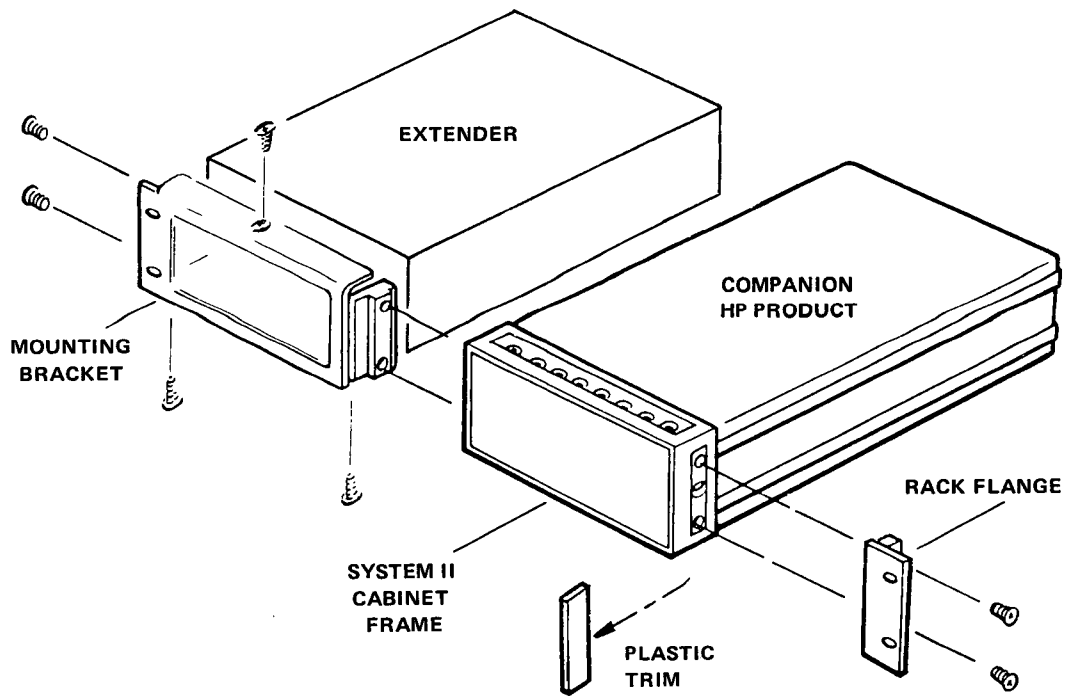

Figure B-4 System 2 Cabinet Rack Mounting

Rack Mounting With HP System 2 Cabinet Products

Use kit HP Part No. 5050-4463 to mount a single 37204A/B Extender in a standard 19 inch rack alongside a half-rack-width 3 1/2 inch high Hewlett-Packard product.

Procedure (refer to Figure B-4):

1. Remove the plastic trim from the front of the Extender. Release the trim by pushing outwards on one of the sides and sliding the trim forward (Figure B-1).
2. Discard the trim.
3. On the companion product, prize off the trim strips on both sides of the front casting and discard.
4. Use 2 screws to attach the rack flange to the side of the companion product.
5. Use 2 screws to attach the mounting bracket to the other side of the companion product.
6. Insert the Extender into the mounting bracket and secure with 3 fixing screws, 2 at the bottom and 1 on the top.
7. Fit the assembly into the rack.